

OUT
OFF
SWITCH
THE



alphaplate

AUTHENTIC

THE AMBITION OF THOSE WHO LOOK FAR AHEAD

The soul of our collections sinks its roots among the waves of the sea, in the harmonious and authentic solitude of boundless spaces, cradled by the sounds of marine life, by its luminous bursts on the surface and those more hidden, immersed in the silent depths of uncontaminated abysses. The spirit of Alphaplate has sailed the seas on luxurious yachts, embellishing walls and supports of elegant environments on crystalline seas and crossing breathtaking HORIZONS, establishing itself over time as a reference point and inspiration in the nautical sector. Journey after journey, what was born to be destined for the sea and prestigious luxury yachts began to be part of a broader dream and an ambitious desire: to explore new SPACES and give new expressions to the exclusivity of a visionary experience. Alphaplate is thus born, from an "Out Of The Switch" intuition in which marine elegance leaves the waves and becomes an integral part of domestic harmony.



INTRO

INDEX

QPLATE

KPLATE

HPLATE

CONTAMINAZIONI

YPLATE

YPLATE67

SOCKET

MATERIALS

FINISHES

TECHNICAL

INDEX



INTRO

INDEX

QPLATE

KPLATE

HPLATE

CONTAMINAZIONI

YPLATE

YPLATE67

SOCKET

MATERIALS

FINISHES

TECHNICAL

INDEX

After having lived it, loved it, and understood it, we decided to gather all the experience gained at sea and bring it into the intimacy of domestic environments with collections of control panels that expressed in every detail the Made in Italy, a universally recognized mark of Excellence. The absolute quality of materials, the artisans who work on them the versatility of in- and daring, yet lines, the re-robustness that nology and cen-tion. Creativity. long and reaso-ver completed ving, which has the bold yet fa- of innovation, in search of a product that would represent a comple-tely new tactile sensory experience, with functionality and practicality equal to the emotions it could evoke. We wanted a common object of everyday use to be transformed into a work of design. An exquisitely Italian challenge to inspire and intrigue the new generations, ferrying them towards a new stylistic and entrepreneurial sensitivity.

MADE IN ITALY

novative design never arrogant, liability and synthesize tech-turies-old tradi-Ours has been a ned search, ne-but still evol-ventured along scinating paths



INTRO

INDEX

QPLATE

KPLATE

HPLATE

CONTAMINAZIONI

YPLATE

YPLATE67

SOCKET

MATERIALS

FINISHES

TECHNICAL

INDEX

An out of the box view and a product that looks far ahead and becomes the beacon of a new idea of luxury.



in which to recognize one's own nuances and reproduce them in a daily use product to which we have given new dignity and prestige, effectively elevating it to the status of a functional design object. Our collections are born to give a heartfelt response to a silent request that may have been considered unrealizable until now: to merge practicality, aesthetics, quality, innovation, tradition. An answer that is now here.

We have dedicated attention to customizing the lines, making them versatile and available in a wide range of finishes and configuration possibilities. Our idea is to give a unique voice to each environment, offering a catalog of options

INTRO

INDEX

QPLATE

KPLATE

HPLATE

CONTAMINAZIONI

YPLATE

YPLATE67

SOCKET

MATERIALS

FINISHES

TECHNICAL

INDEX

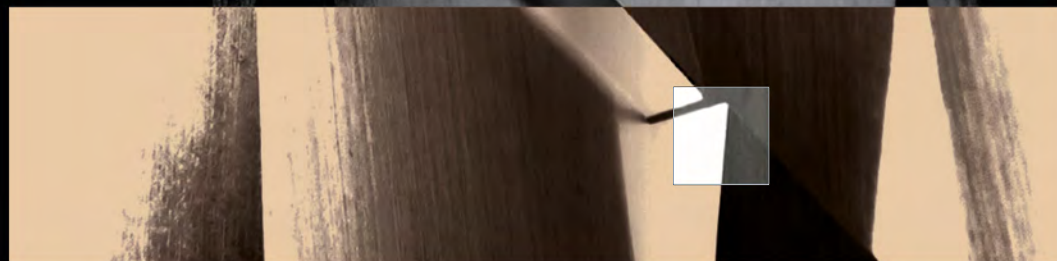

2 INTRO

9 INDEX

12 QPLATE

22 KPLATE

30 HPLATE

40 CONTAMINAZIONI

48 YPLATE

54 YPLATE 67

58 SOCKETS

60 MATERIALS

64 FINISHES

72 TECHNICAL

A journey into design, where functionality becomes a multisensory experience.

Original collections, evolutions imbued with a unique character for a luxury that knows how to be discreet and is the result of patient study, courageous experimentation, and a vision that has aimed for one goal: excellence.

ALPHA PLATE

COLLECTION

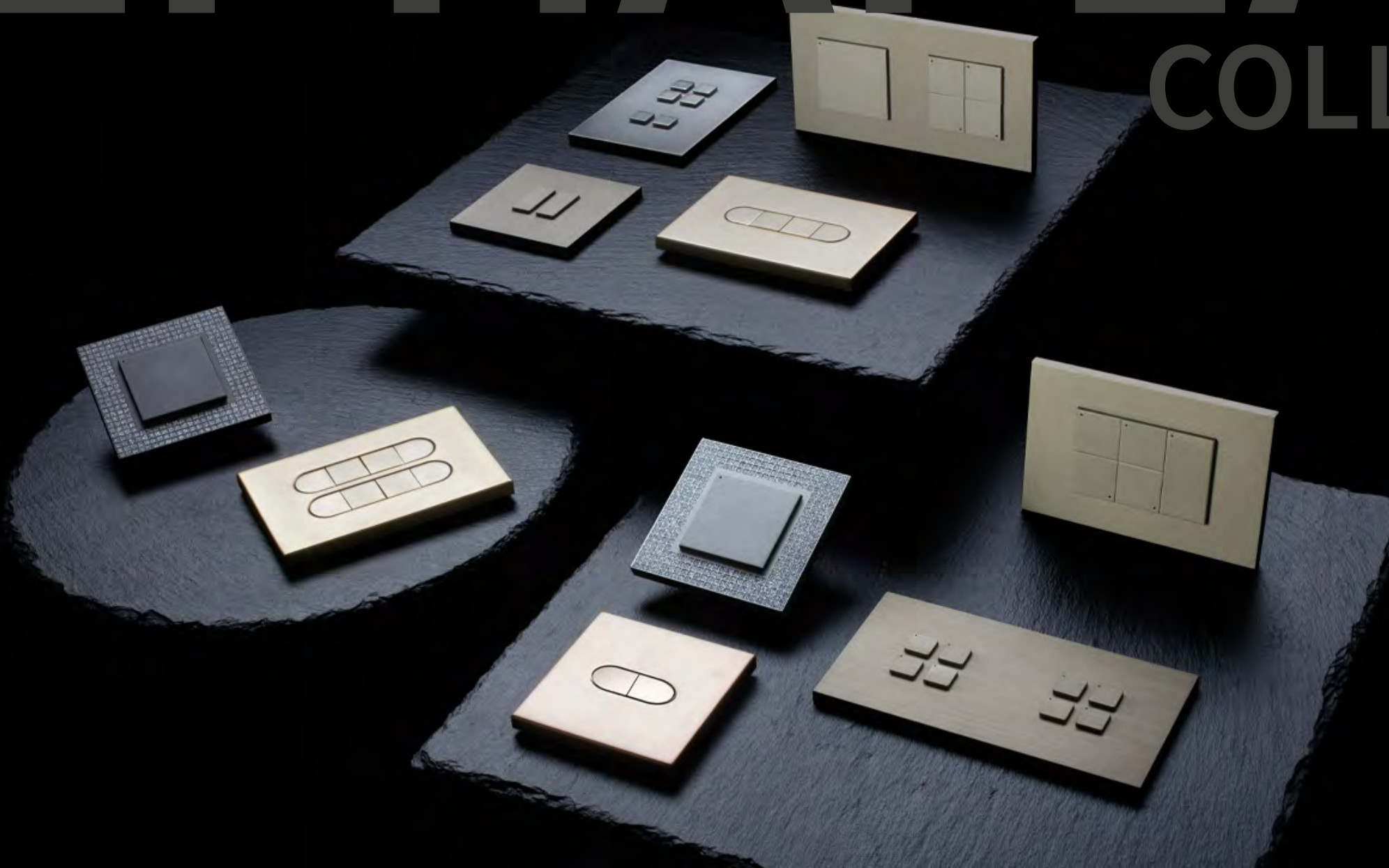

INTRO

INDEX

QPLATE

KPLATE

HPLATE

CONTAMINAZIONI

YPLATE

YPLATE67

SOCKET

MATERIALS

FINISHES

TECHNICAL

INDEX

QPLATE



INTRO

INDEX

QPLATE

KPLATE

HPLATE

CONTAMINAZIONI

YPLATE

YPLATE67

SOCKET

MATERIALS

FINISHES

TECHNICAL

EXPERIENCE

INTRO

INDEX

QPLATE

KPLATE

HPLATE

CONTAMINAZIONI

YPLATE

YPLATE67

SOCKET

MATERIALS

FINISHES

TECHNICAL

INDEX

THE DELICACY OF A CONCRETE AESTHETIC, THE HARMONIOUS EMBRACE BETWEEN KEYS AND THE STRUCTURE THAT WELCOMES THEM.

QPLATE

Details and shapes redefining the style of an environment.

The smooth surface and the flush, crescent-shaped keys embellish the softened frame, lending softness to an element that expresses its charm discreetly, with total customization of colors and buttons to make it even more attractive. A refined grace that does not overshadow functionality, with backlighting of the icons sealing a perfect blend of aesthetics and practicality.

EMOTIONS

DESIGNED TO CAPTURE
EMOTIONS.



INTRO

INDEX

QPLATE

KPLATE

HPLATE

CONTAMINAZIONI

YPLATE

YPLATE67

SOCKET

MATERIALS

FINISHES

TECHNICAL

INDEX

EXTREME VERSATILITY

INTRO

INDEX

QPLATE

KPLATE

HPLATE

CONTAMINAZIONI

YPLATE

YPLATE67

SOCKET

MATERIALS

FINISHES

TECHNICAL

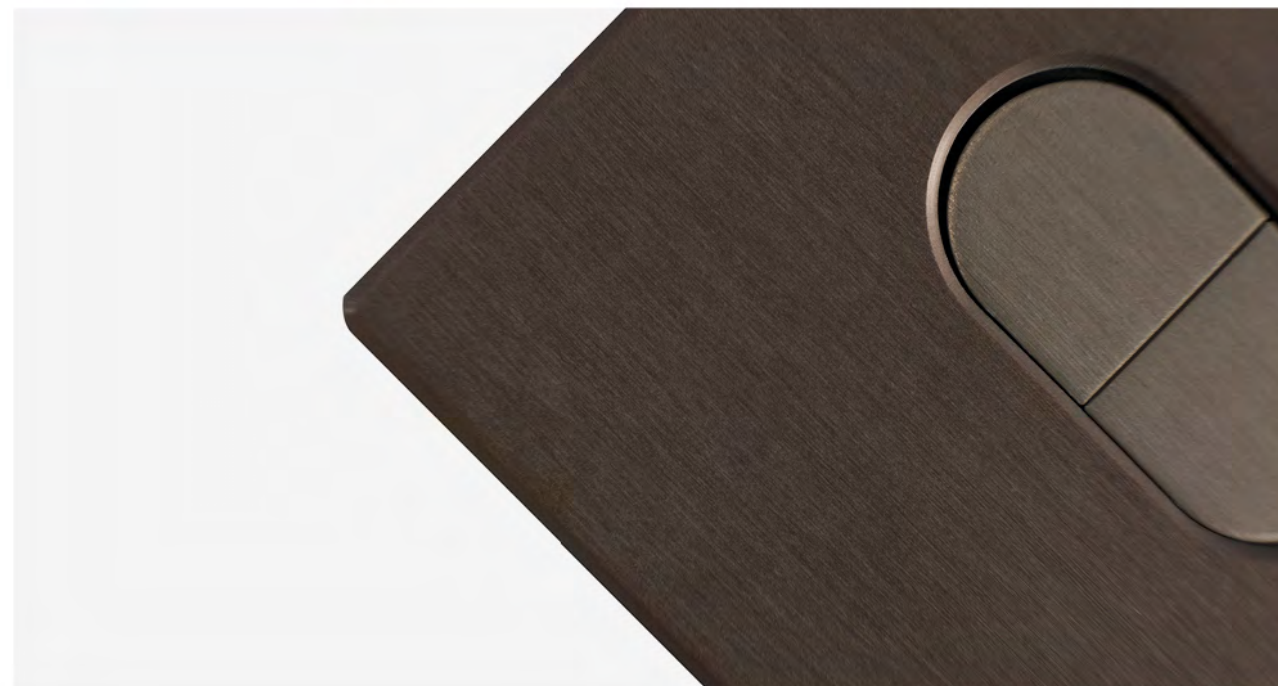
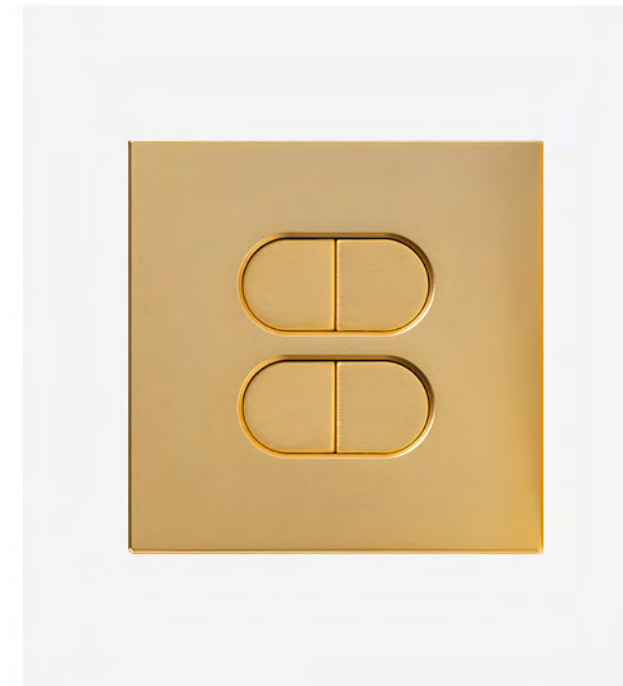

CREATIVITY

PLOTTING TOGETHER THE NEW
ROUTES OF DESIGN.

INTRO

INDEX

QPLATE

KPLATE

HPLATE

CONTAMINAZIONE 150x20 mm

YPLATE

YPLATE67

SOCKET

MATERIALS

FINISHES

TECHNICAL

< INDEX >

The Yachtica Design & Innovation Prize was established through a close collaboration with the ISIA Institute of Florence during 2019/2020. The goal was to invest in and help the growth of Generation Z designers around the concept of "High Craftsmanship," where the notion of luxury is rooted in refined, high-quality production, often custom and limited-edition. Following meticulous research, the Product Design class presented several interesting proposals, with the winning concept being "Gemma" by Fabiola Pignatelli.

KPLATE



- INTRO
- INDEX
- QPLATE
- KPLATE**
- HPLATE
- CONTAMINAZIONI
- YPLATE
- YPLATE67
- SOCKET
- MATERIALS
- FINISHES
- TECHNICAL

DIFFERENT

THE UNIQUENESS OF AN INTUITION YOU CAN RECOGNIZE WITH YOUR EYES CLOSED: ALL IT TAKES IS A TOUCH.

INTRO

INDEX

QPLATE

KPLATE

HPLATE

CONTAMINAZIONI

YPLATE

YPLATE67

SOCKET

MATERIALS

FINISHES

TECHNICAL

INDEX

KPLATE

Evolution between technology and design.

The robustness of a product that manages to convey reliability and durability while also exuding delicacy and elegance, adding personality to every space. The soft touch keys make the tactile sensation prominent, transforming an ordinary gesture into a sudden and surprising aesthetic experience. The versatility of extreme customization that includes shapes and colors, ensuring the essence remains unchanged in every combination.



I < FEELING

TOUCH UPON A NEW WHOLE
UNIVERSE OF SENSATIONS.



INTRO

INDEX

QPLATE

KPLATE

HPLATE

CONTAMINAZIONI

YPLATE

YPLATE67

SOCKET

MATERIALS

FINISHES

TECHNICAL

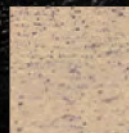

<
INDEX
>

- INTRO
- INDEX
- QPLATE
- KPLATE**
- HPLATE
- CONTAMINAZIONI
- YPLATE
- YPLATE67
- SOCKET
- MATERIALS
- FINISHES
- TECHNICAL

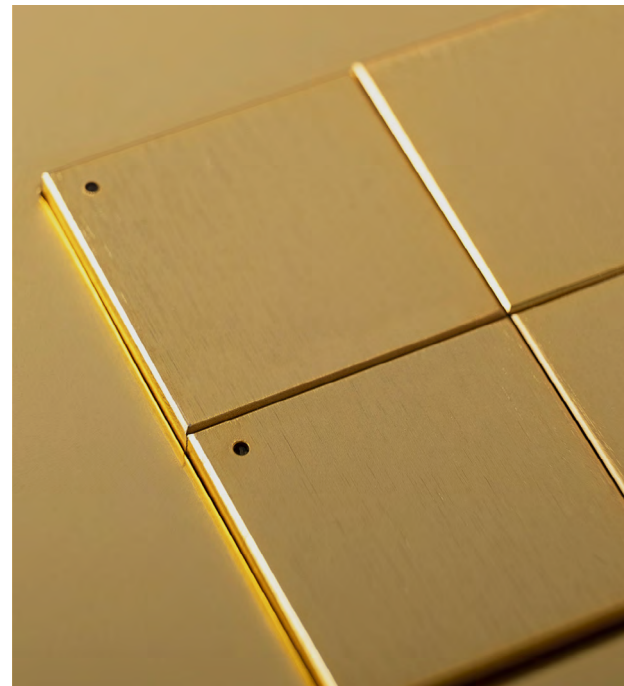
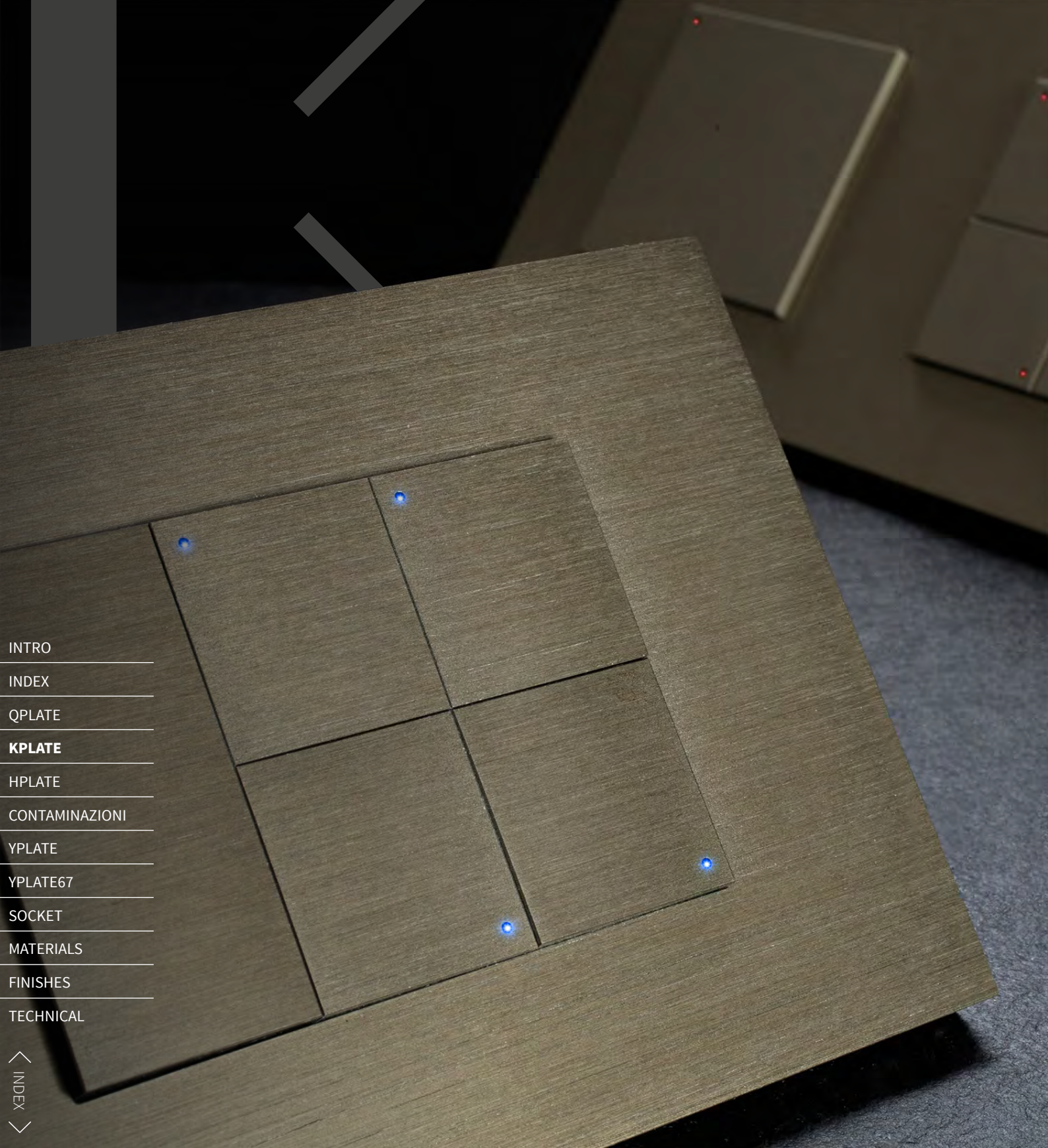

H HPLATE

INFINITE OPTIONS THAT
ADAPT TO YOUR STYLE
AND YOUR DESIRES.

INTRO

INDEX

QPLATE

KPLATE

HPLATE

CONTAMINAZIONI

YPLATE

YPLATE67

SOCKET

MATERIALS

FINISHES

TECHNICAL

INDEX

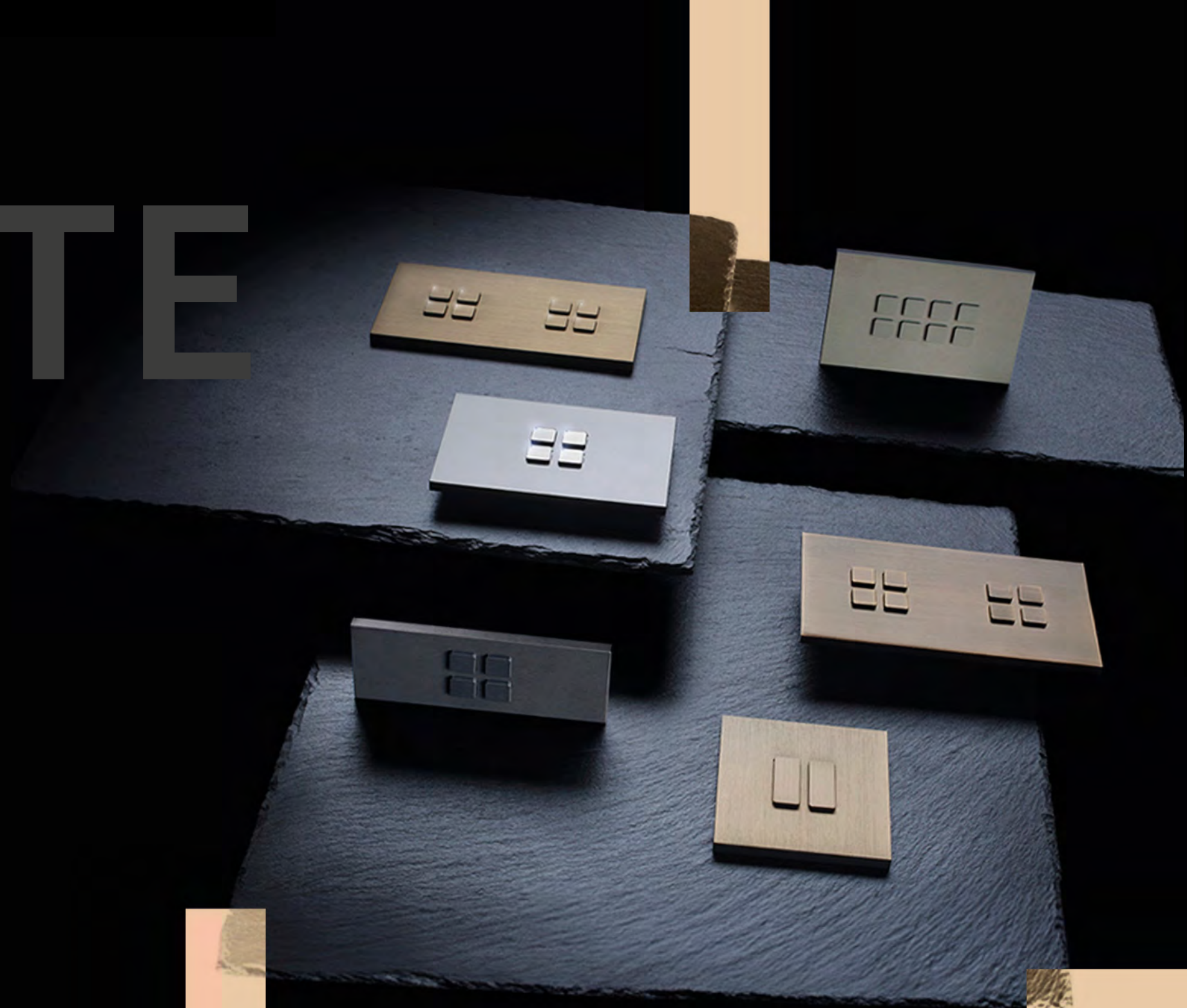



CONFINED SPACES HAVE ALWAYS BEEN AN OBSTACLE TO QUALITY DESIGN. NOT ANYMORE.

INTRO

INDEX

QPLATE

KPLATE

HPLATE

CONTAMINAZIONI

YPLATE

YPLATE67

SOCKET

MATERIALS

FINISHES

TECHNICAL

INDEX

HPLATE

Ideas that give luxury different perspectives.

The fluidity of the lines flows along the surface, blending with the buttons, creating a unique, pleasant, and surprising multisensory experience. The activation is accompanied by a luminous feedback that can be expressed with pinpoint lighting or with a suggestive mushroom-like backlighting.

H CUSTOMIZE

PLENTY OF CHOICE.

INTRO

INDEX

QPLATE

KPLATE

HPLATE

CONTAMINAZIONI

YPLATE

YPLATE67

SOCKET

MATERIALS

FINISHES

TECHNICAL

INDEX

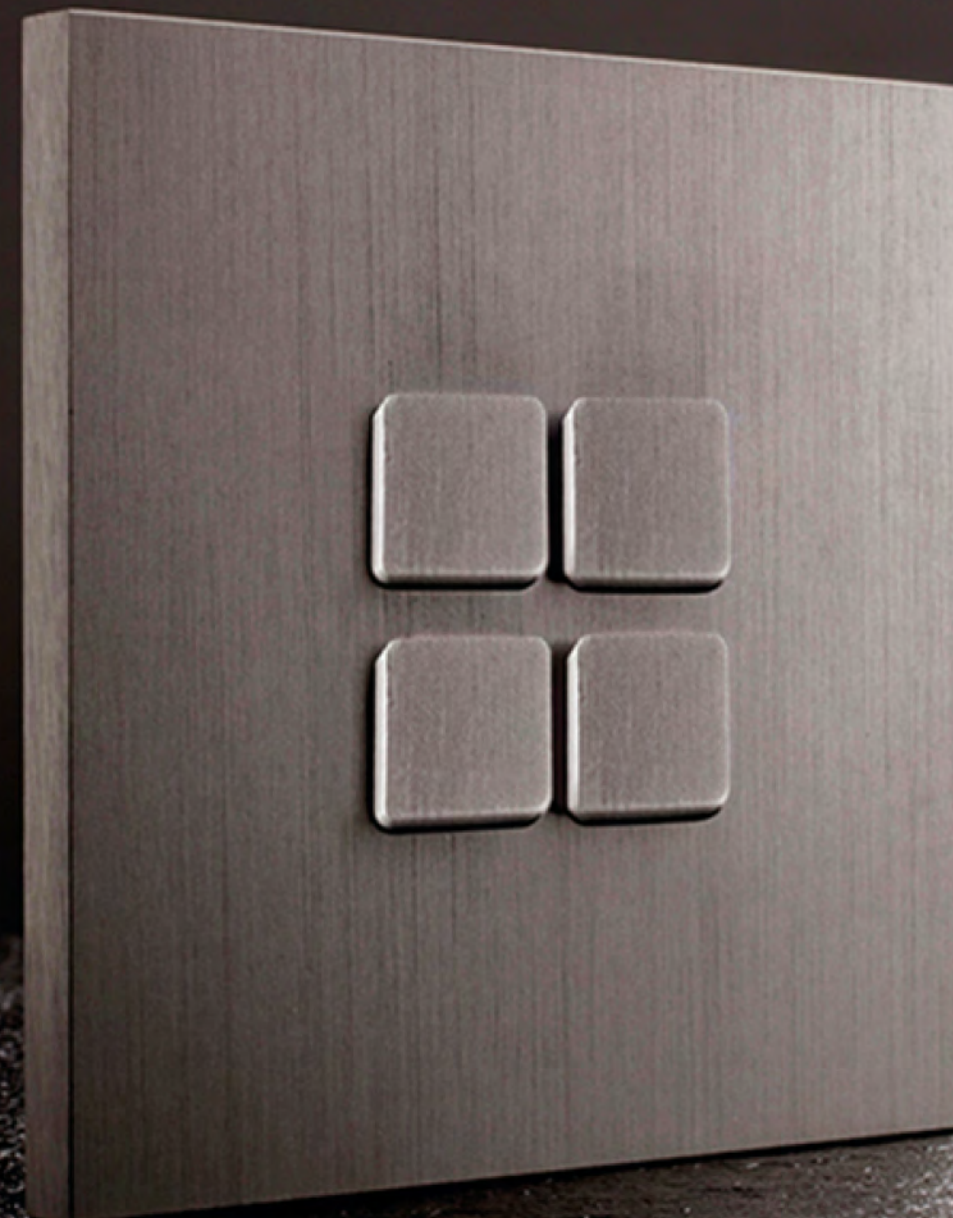

- INTRO
- INDEX
- QPLATE
- KPLATE
- HPLATE**
- CONTAMINAZIONI
- YPLATE
- YPLATE67
- SOCKET
- MATERIALS
- FINISHES
- TECHNICAL

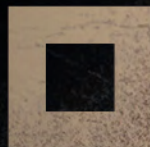

THE VERSATILITY OF SHAPES AND COLORS, SPECIAL FINISHES, TOTAL CUSTOMIZATION OF BUTTONS FOR A CONFIGURATION THAT CAN LISTEN TO THE VOICE OF YOUR PERSONALITY.

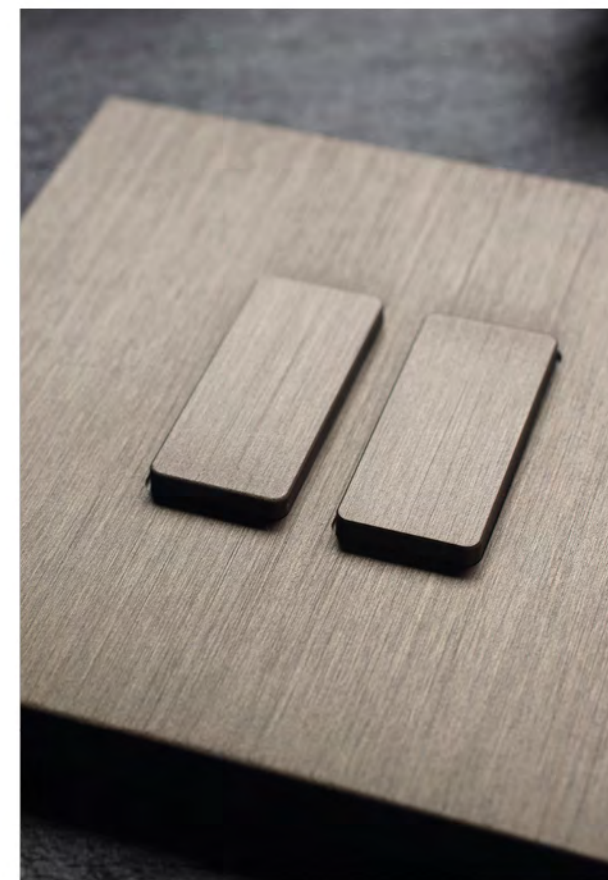

Buttons of every shape, from the most sinuous lines to the sharpest ones, in quantity and with the type of backlighting most suitable for your needs, for a customization that covers every detail.



- INTRO
- INDEX
- QPLATE
- KPLATE
- HPLATE**
- CONTAMINAZIONI
- YPLATE
- YPLATE67
- SOCKET
- MATERIALS
- FINISHES
- TECHNICAL

HPLATE SLIM

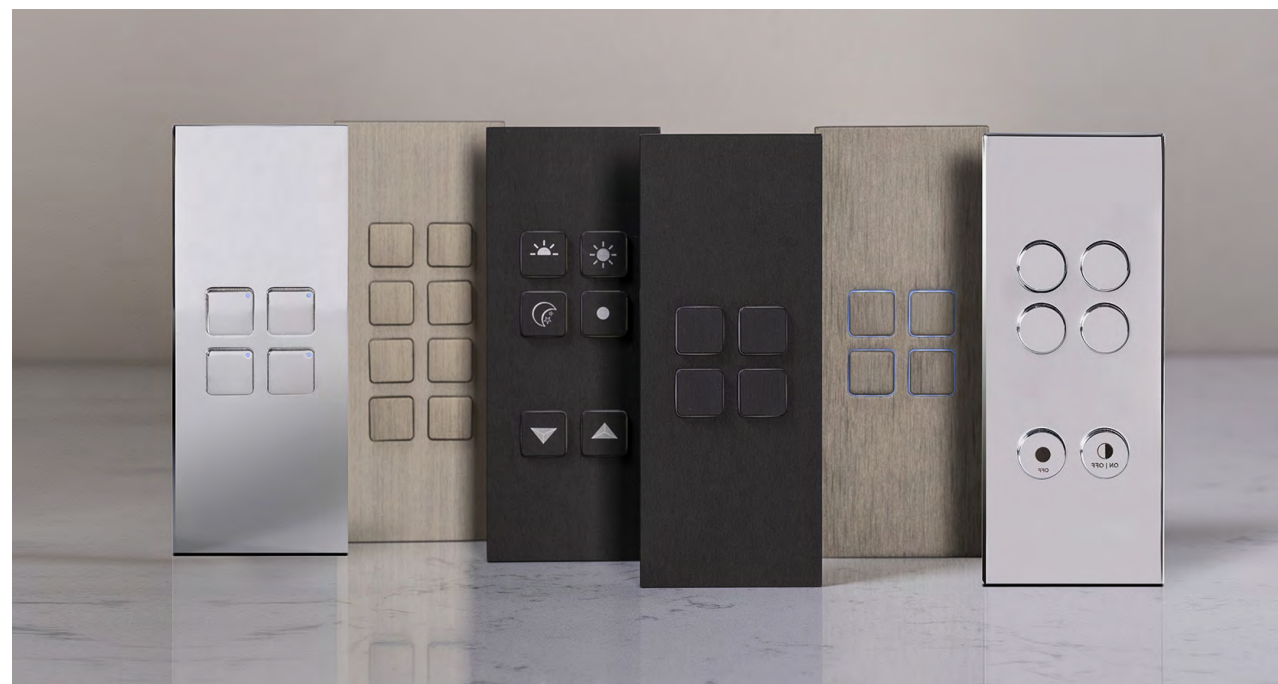
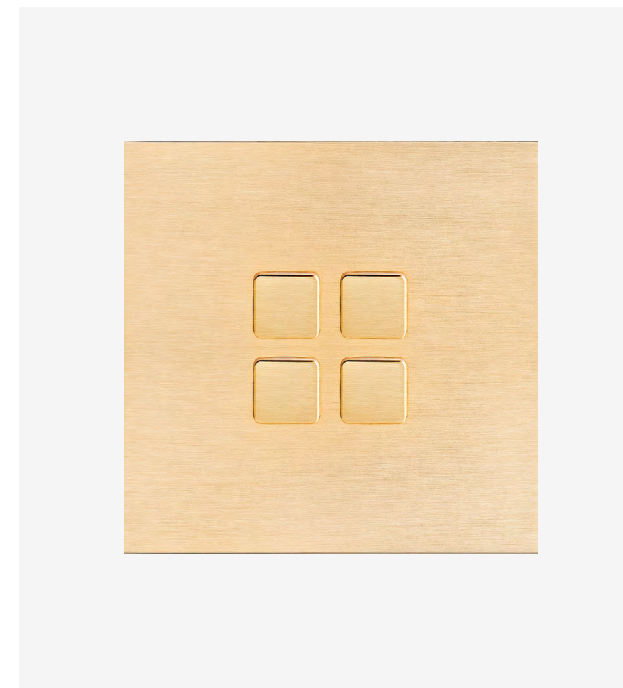

CONTAMINAZIONI

DIFFERENT ORIGINS, PATHS,
AND DIVERSE STORIES FOR
A REVOLUTIONARY MATCH.



- INTRO
- INDEX
- QPLATE
- KPLATE
- HPLATE
- CONTAMINAZIONI**
- YPLATE
- YPLATE67
- SOCKET
- MATERIALS
- FINISHES
- TECHNICAL

in collaboration with
DiamArt
Micro Diamond Surfaces



INTRO

INDEX

QPLATE

KPLATE

HPLATE

CONTAMINAZIONI

YPLATE

YPLATE67

SOCKET

MATERIALS

FINISHES

TECHNICAL

INDEX

GEOMETRIC FORMS BENT TO THE
INSTINCT OF AN INSPIRATION THAT
UNITES DISTANT WORLDS.

PRECIOUS

From the collaboration with Diamond Art comes an innovative and enormously prestigious product that defines a new chapter in luxury. Three hundred customizable holes adorned with micro-diamonds of different colors enrich the surface, transforming it into a canvas of light and reflection. Each piece is certified with carat evaluation and quality of micro-diamonds, for a perfection that surprises.

DIAMOND

A JEWEL THAT CAPTURES
YOUR GAZE.

INTRO

INDEX

QPLATE

KPLATE

HPLATE

CONTAMINAZIONI

YPLATE

YPLATE67

SOCKET

MATERIALS

FINISHES

TECHNICAL

INDEX

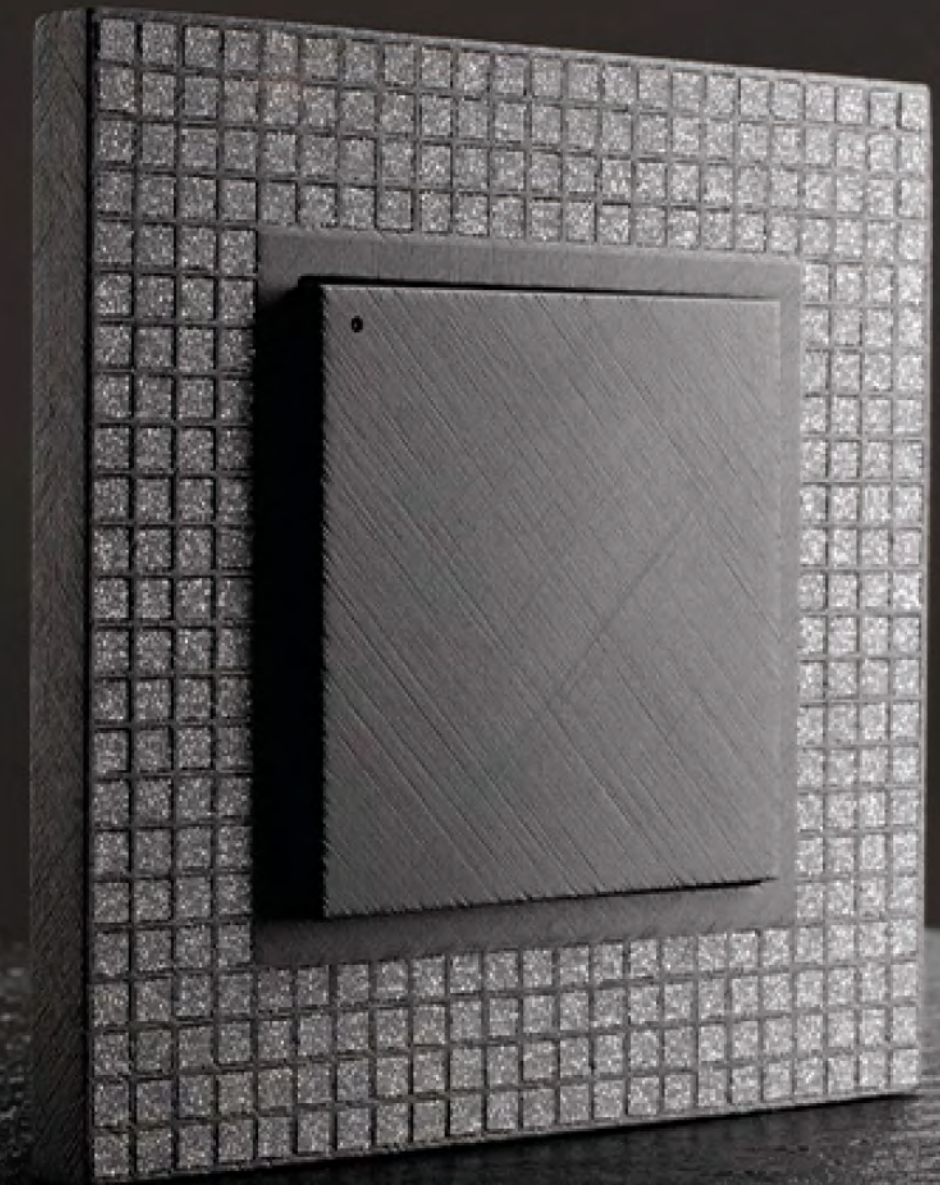

- INTRO
- INDEX
- QPLATE
- KPLATE
- HPLATE
- CONTAMINAZIONI**
- YPLATE
- YPLATE67
- SOCKET
- MATERIALS
- FINISHES
- TECHNICAL

DIAMOND

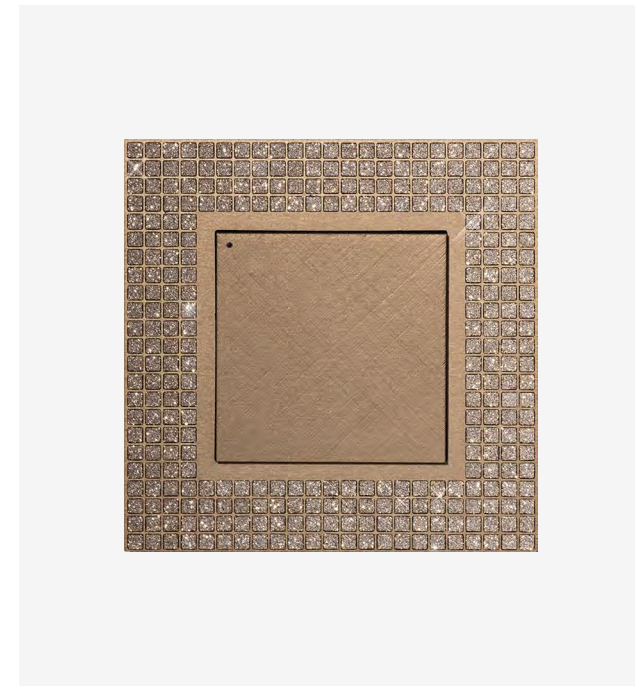
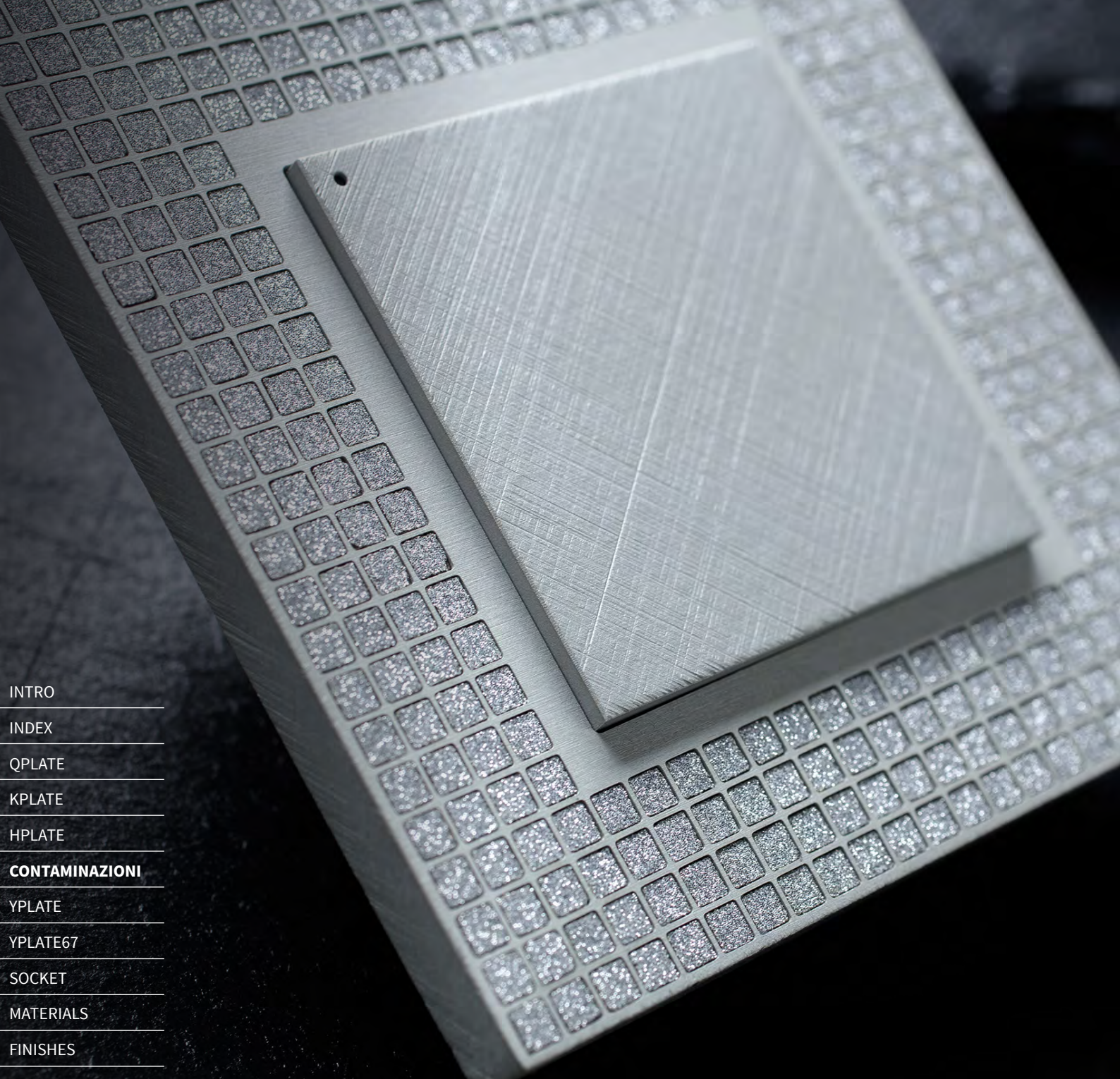

YPLATE

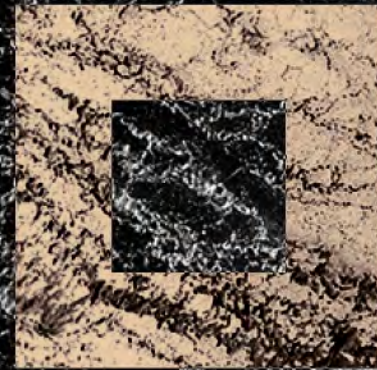

INTRO

INDEX

QPLATE

KPLATE

HPLATE

CONTAMINAZIONI

YPLATE

YPLATE67

SOCKET

MATERIALS

FINISHES

TECHNICAL



YPLATE

Refined minimalism for superior performance.

ESSENTIAL IN FORM AND DIMENSION,
CUSTOMIZABLE IN EVERY DETAIL
AND WITH A SERIE OF EXCLUSIVE
COORDINATED SOCKETS.

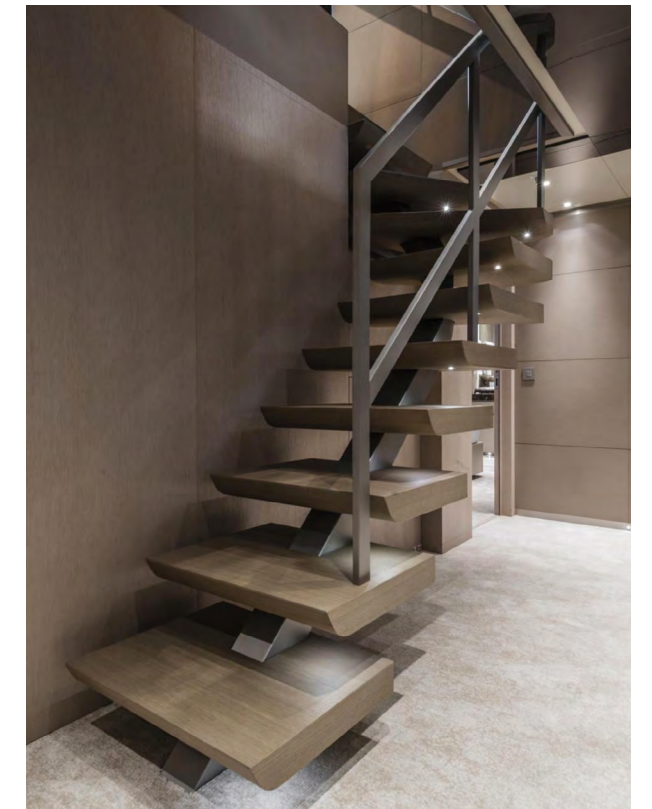

Captivating design for enhanced reliability further implemented by a bespoke process that prevents potential internal oxidations. Robustness stemming from the world of luxury yachts, for which the line was originally conceived. A robustness derived from the world of luxury yachts, for which the line was originally conceived.

INTRO

INDEX

QPLATE

KPLATE

HPLATE

CONTAMINAZIONI

YPLATE

YPLATE67

SOCKET

MATERIALS

FINISHES

TECHNICAL

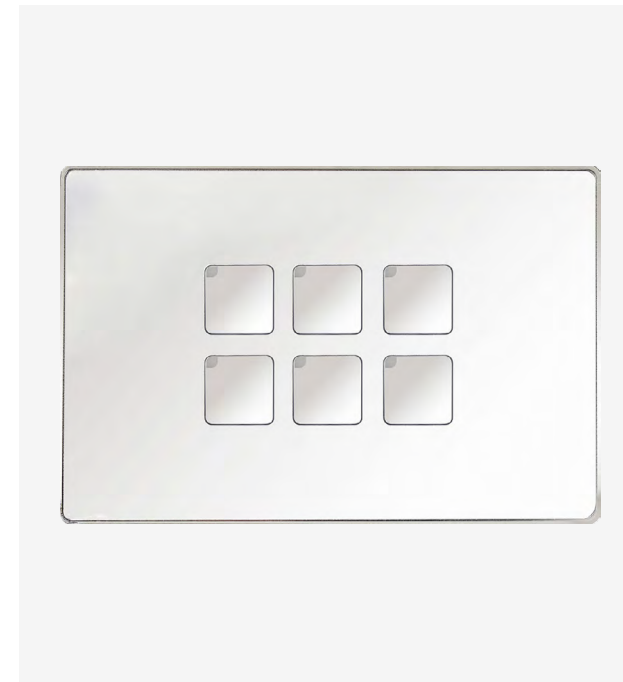

YPLATE67

ELEVATE YOUR STYLE,
ANYWHERE.

INTRO

INDEX

QPLATE

KPLATE

HPLATE

CONTAMINAZIONI

YPLATE

YPLATE67

SOCKET

MATERIALS

FINISHES

TECHNICAL

INDEX



THE PERFECT LINE TO EXPERIENCE
 THE OUTDOORS WITH THE TASTE AND
 ELEGANCE OF A PRESTIGIOUS INTERIOR.
 CUSTOMIZABLE FINISHES TO EXPRESS
 YOUR PERSONALITY EVEN IN OUTDOOR
 FURNISHINGS.



Wellness areas, spas, and outdoor furnishings require accessories with greater solidity, here ensured by a front label with extremely high resistance, entirely waterproof effectively isolating the electronic components.

SOCKET PLATES

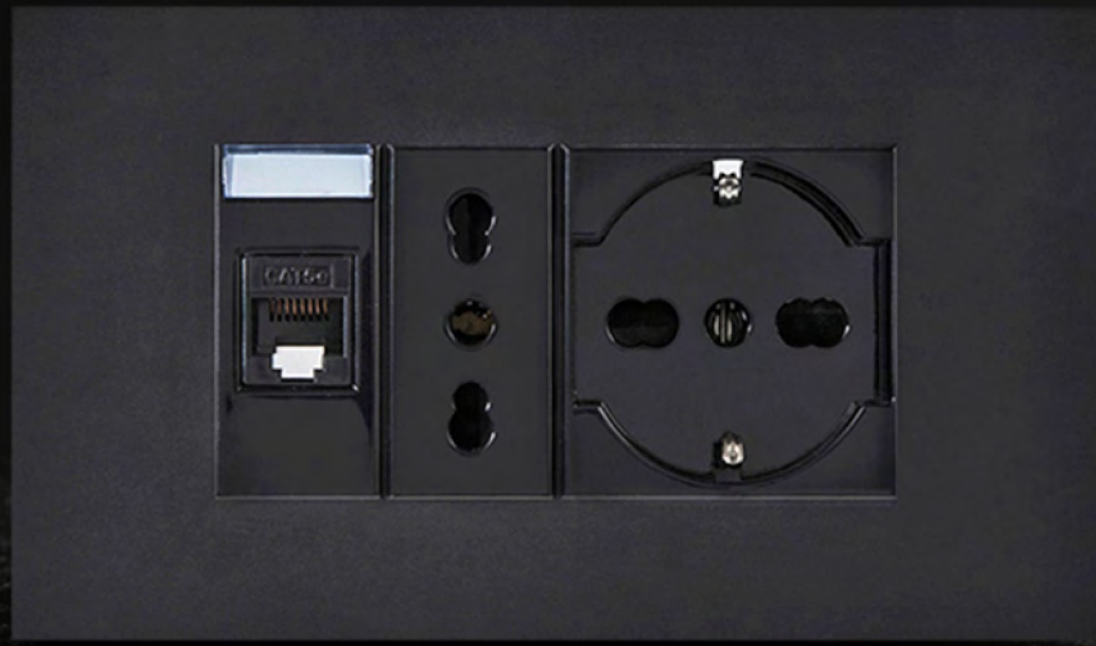

SOCKET

Enclose everyday life
in a perfect frame.

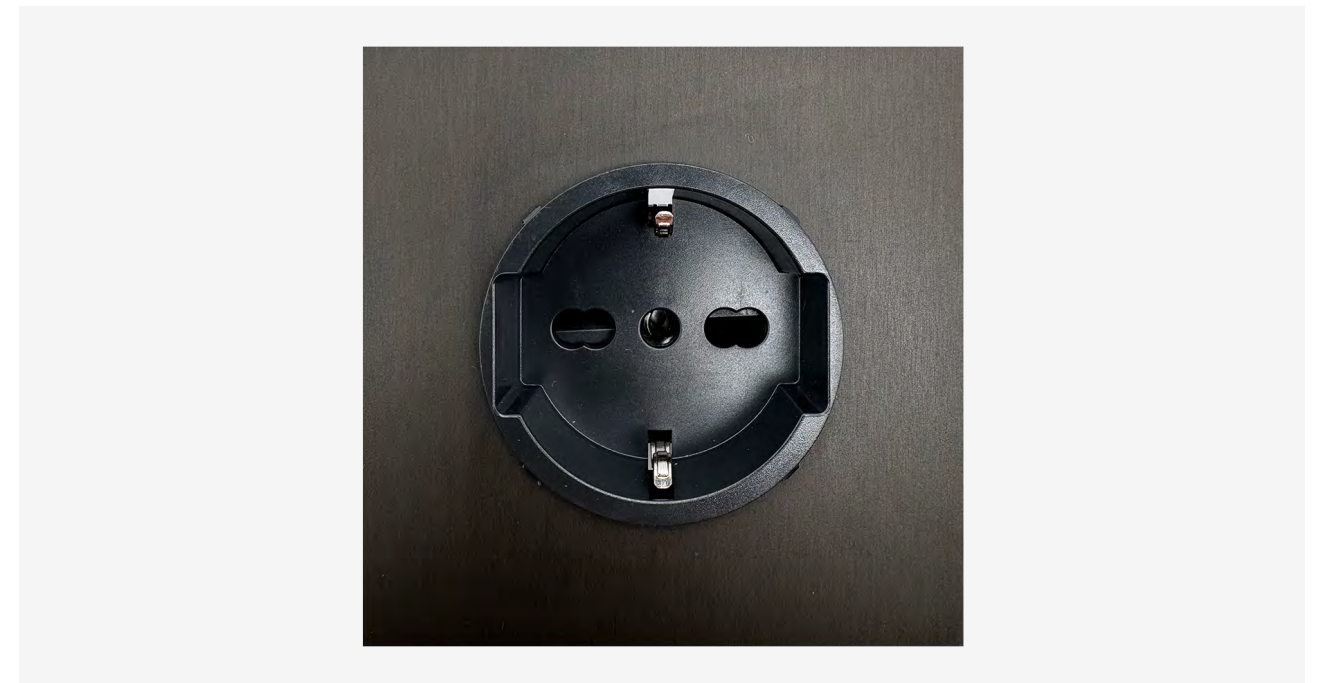

INTRO

INDEX

QPLATE

KPLATE

HPLATE

CONTAMINAZIONI

YPLATE

YPLATE67

SOCKET

MATERIALS

FINISHES

TECHNICAL

< INDEX >

MATERIALS



INTRO

INDEX

QPLATE

KPLATE

HPLATE

CONTAMINAZIONI

YPLATE

YPLATE67

SOCKET

MATERIALS

FINISHES

TECHNICAL

INDEX

ALUMINIUM

Aluminum, its chemical symbol (Al.) Given its characteristics, is the most used metal, after iron, for the manufacture of millions of products. One of its greatest advantages are:



INTRO

INDEX

QPLATE

KPLATE

HPLATE

CONTAMINAZIONI

YPLATE

YPLATE67

SOCKET

MATERIALS

FINISHES

TECHNICAL

INDEX



RECYCLABLE

Aluminum can be recycled 100% and countless times without losing its original characteristics that remain unchanged indefinitely, even following numerous recycling phases, that is when the metal acquires the definition of "aluminum from being primary aluminum. recycling "or" secondary aluminum ". Infinitely reusable and 100% recyclable Producing aluminum from scratch has an energy cost of 13 kWh / kg. The production of recycled aluminum cuts this cost by 95%.



DUCTILITY AND MALLEABILITY

Aluminum is easily workable and suitable for undergoing processing processes at both high and low temperatures.



AMAGNETISM

The low magnetizability of the materials used in our products ensures a minimal risk of unwanted magnetic interference.



CORROSION RESISTANCE

Aluminum is a material that immediately oxidizes upon contact with air, creating a protective layer on its surface that makes it particularly resistant to water, wind, and some chemicals. This characteristic makes it the most widely used metal in the transportation, construction, and building industries. It does not require protective coatings, a feature that positively affects the overall weight of the object produced, making it lighter.



LIGHTNESS

With the same volume, aluminum weighs about 1/3 of copper and steel.



AESTHETICS

The ease of finishing in various techniques, along with its brightness, makes aluminum the perfect material for such a catalog of a wide range of options.

FINISHES

INTRO

INDEX

QPLATE

KPLATE

HPLATE

CONTAMINAZIONI

YPLATE

YPLATE67

SOCKET

MATERIALS

FINISHES

TECHNICAL

INDEX



PAINTINGS

The spraying painting is made with highresistance paints and primer treatments for anchoring to the underlying metal material. It is performed in a protected environment to avoid dust and the paint is sprayed directly on the surface to be treated.

ANODIZING

Anodization or anodic oxidation, applicable exclusively to aluminum, is a non-spontaneous electrochemical process through which a protective layer is formed over the surface. The technical anodizing treatment of aluminum alloys can be provided with the natural color of the aluminum or colored; it is also requested for its aesthetic qualities, since the visual aspect is a decisive factor that must be preserved overtime. The purpose of the anodizing treatment is to improve the properties of surface hardness, resistance to wear and abrasion and to enhance the aesthetic appearance of the product.

GALVANIZATION

Chrome plating, Nickel plating, Bronzing, Gilding Industrial process consisting in covering a metal product with a thin and strongly adherent layer of another metal in order to protect it from corrosion and it is also an effective method for adding elegant metallic finishes to industrial, design and artistic products.

ANODIZED FINISHES

FINISHES MATTE

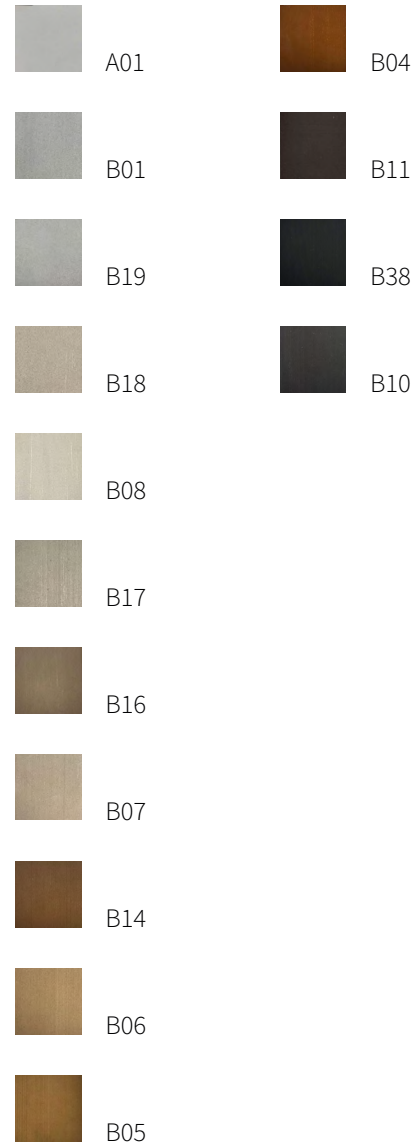

FINISHES GLOSSY

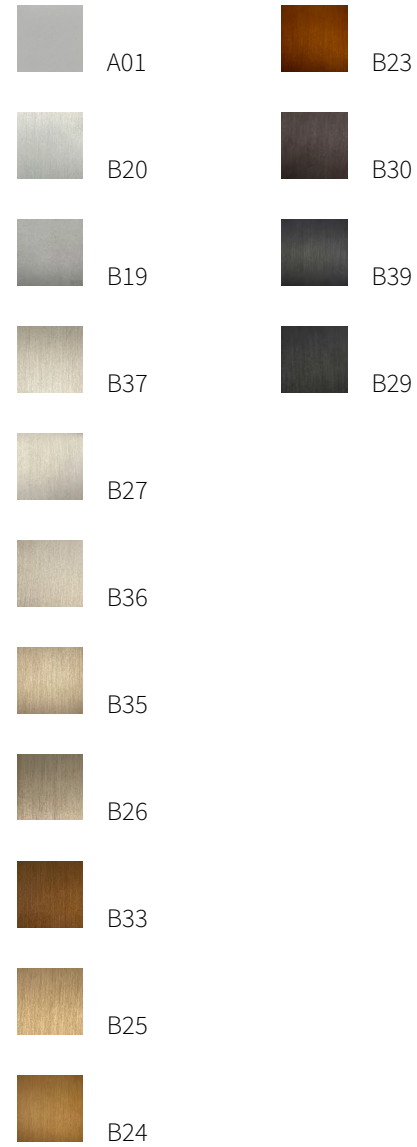

SPECIAL ANODIZED FINISHES

FINISHES MATTE

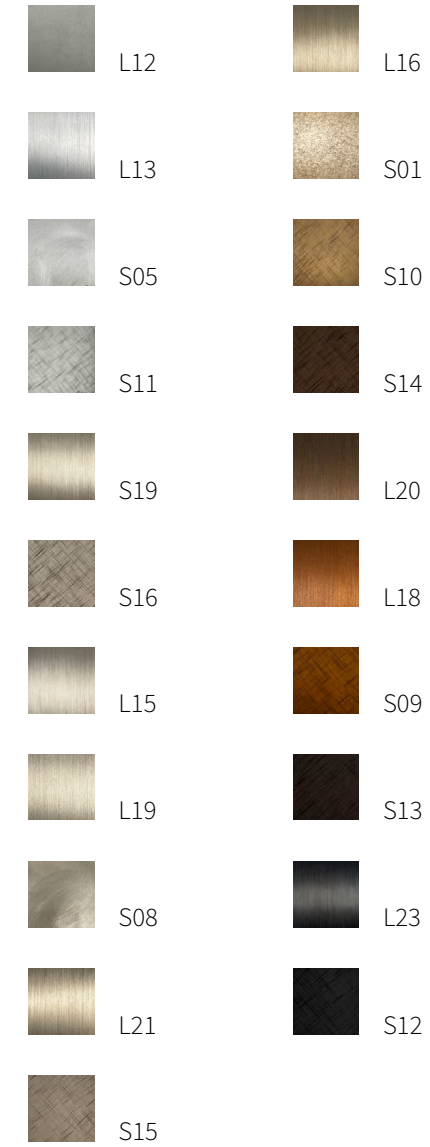

FINISHES GLOSSY

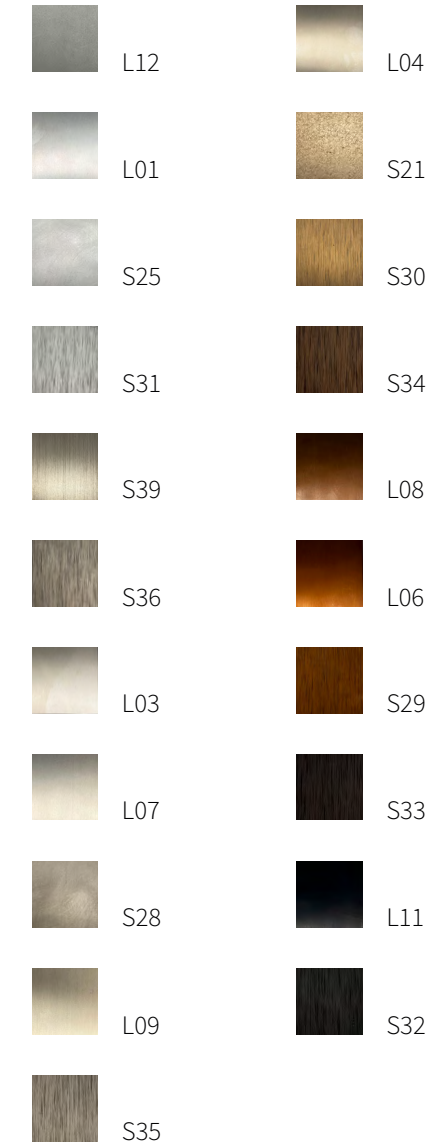

GALVANIC CHROME & GLIDING FINISHES

ART FINISHES

FINISHES

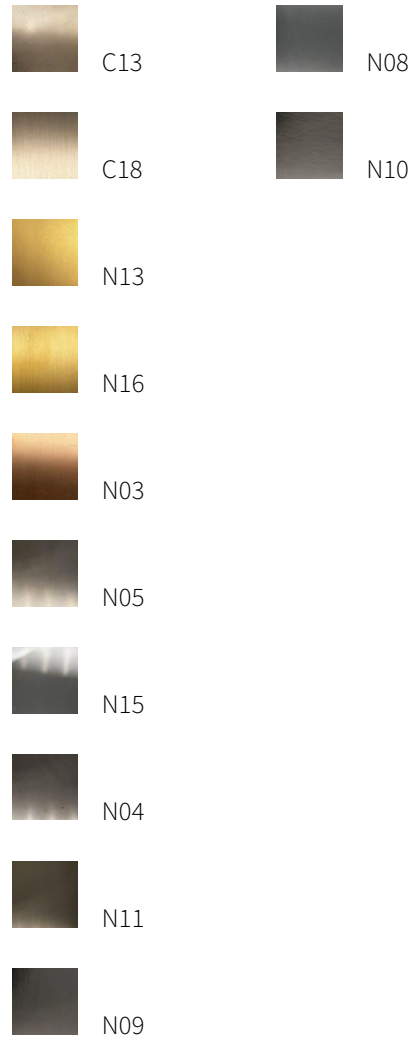

FINISHES



TECHNICAL



SPECIFICATIONS

[INTRO](#)

[INDEX](#)

[QPLATE](#)

[KPLATE](#)

[HPLATE](#)

[CONTAMINAZIONI](#)

[YPLATE](#)

[YPLATE67](#)

[SOCKET](#)

[MATERIALS](#)

[FINISHES](#)

[TECHNICAL](#)

◀ INDEX ▶



plate

ENDLESS LAYOUT AND BUTTONS COMBINATIONS

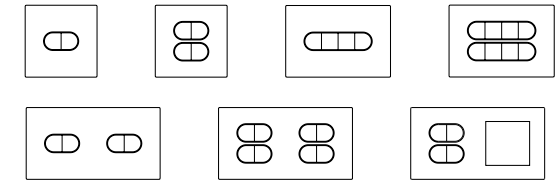

BUTTONS

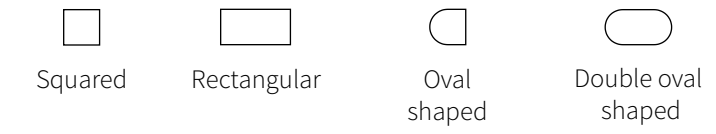

BACKLIT WHITE LED



ICONS & SYMBOLS

Wide range of backlight icons

ELECTRONICS



COMING SOON KNX



USB-C CHARGERS

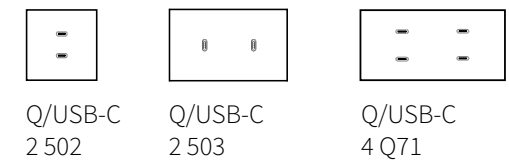

AVAILABLE SIZE

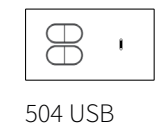
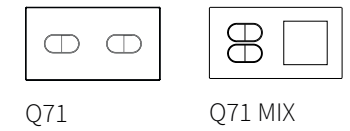

SOCKETS

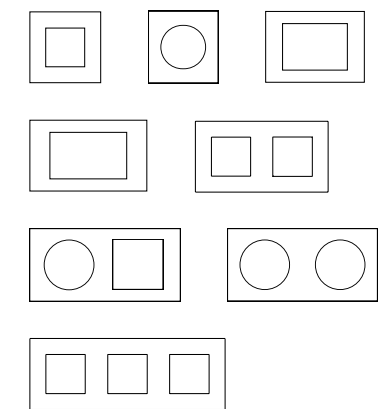

CUSTOM SHAPES AVAILABLE

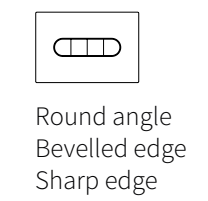

QPLATE® 502

MECHANICAL CHARACTERISTICS (MM)

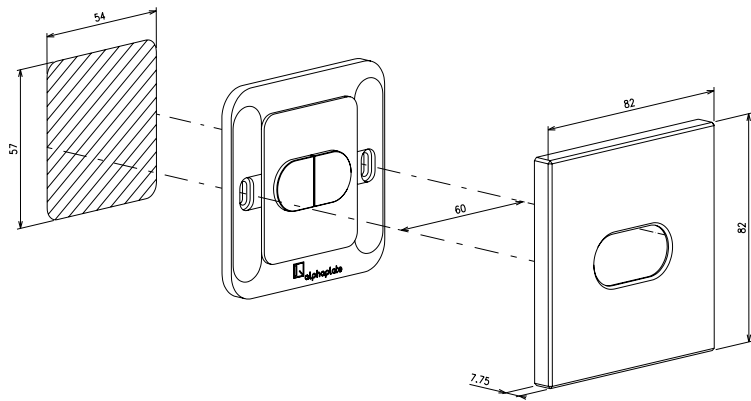

DIMENSIONS (MM)

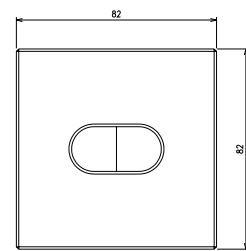

Front view

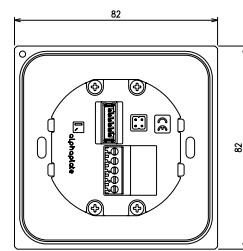

Passive

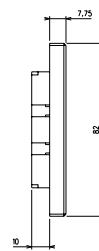

Passive side view

QPLATE® 502

MECHANICAL CHARACTERISTICS (MM)

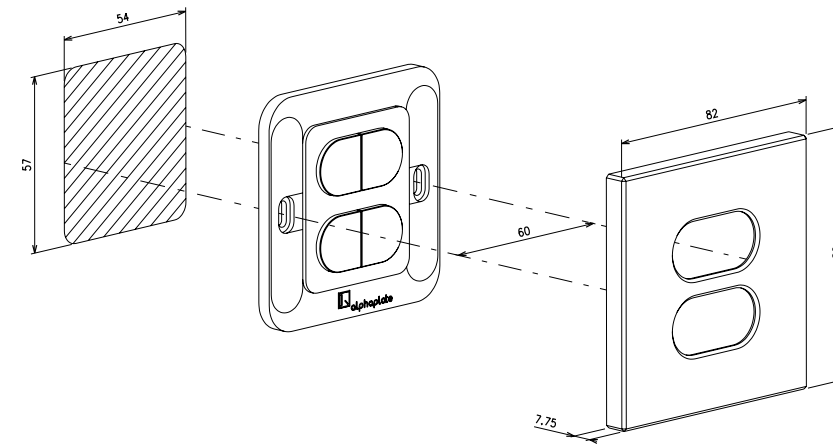

DIMENSIONS (MM)

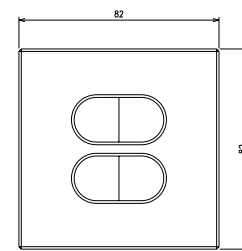

Front view

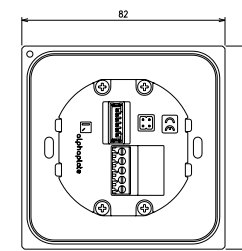

Passive

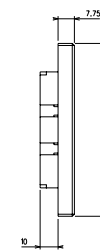

Passive side view

QPLATE® 503

MECHANICAL CHARACTERISTICS (MM)

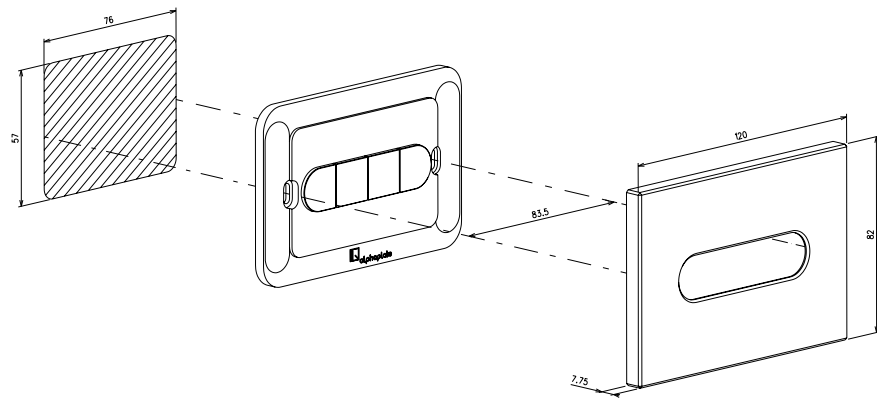

DIMENSIONS (MM)

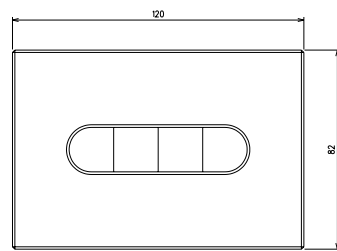

Front view

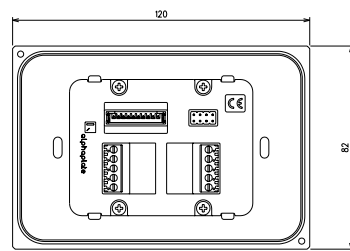

Passive

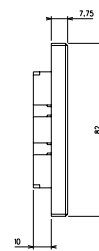

Passive side view

QPLATE® 503

MECHANICAL CHARACTERISTICS (MM)

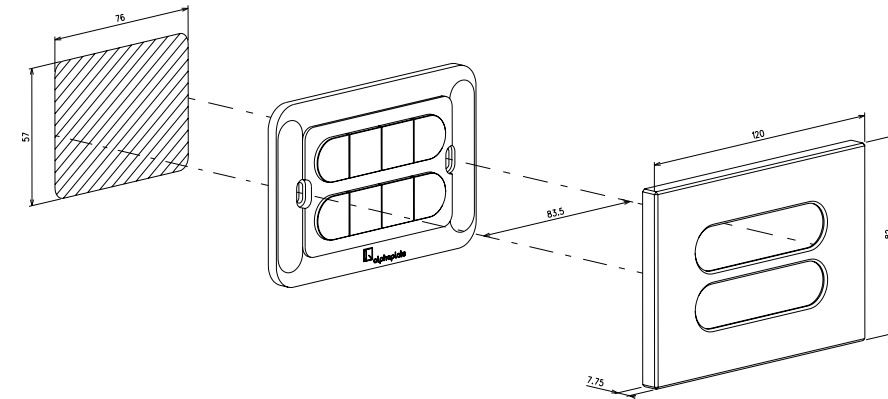

DIMENSIONS (MM)

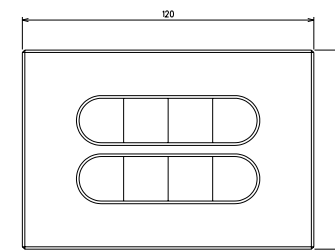

Front view

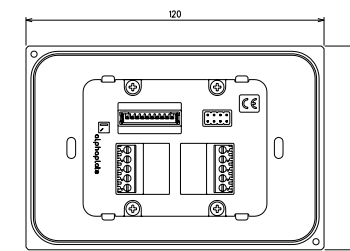

Passive

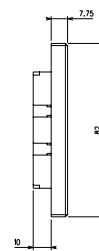

Passive side view

QPLATE® Q71

MECHANICAL CHARACTERISTICS (MM)

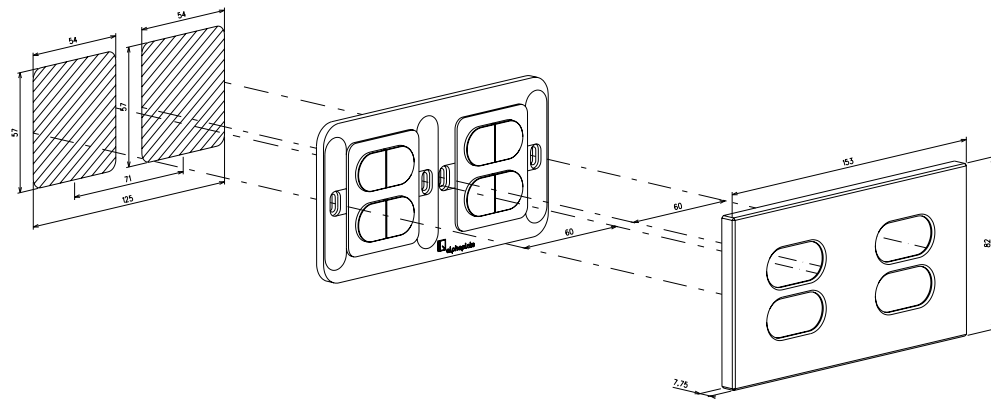

DIMENSIONS (MM)

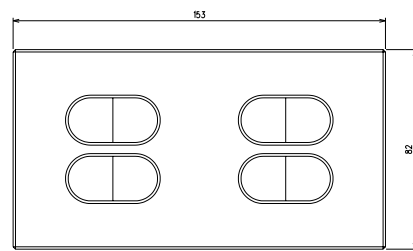

Front view

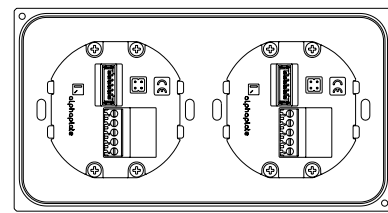

Passive

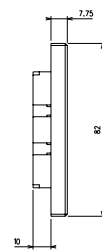

Passive side view

QPLATE® SOCKET

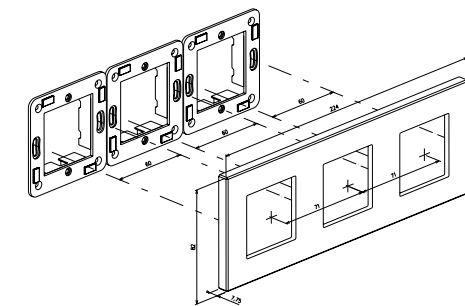
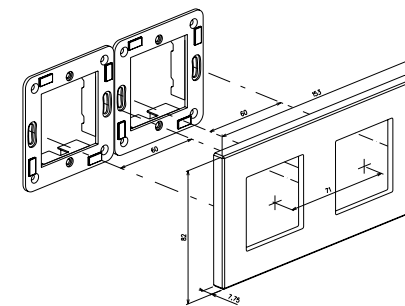
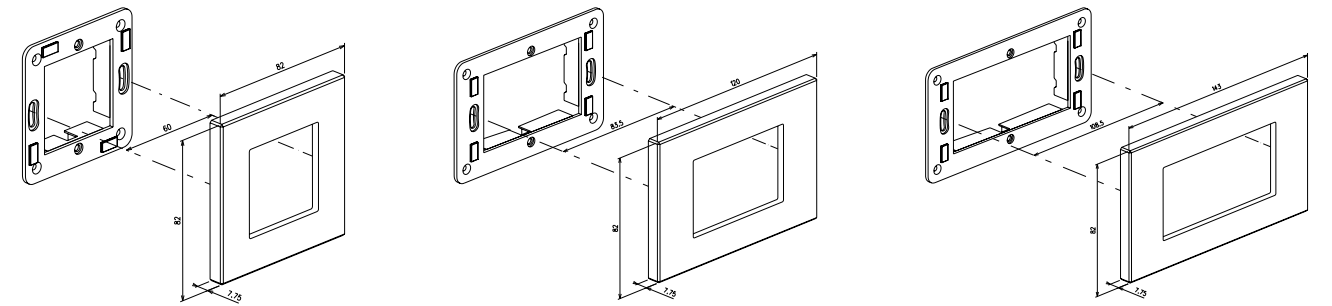

QPLATE® BACKLIT ICONS



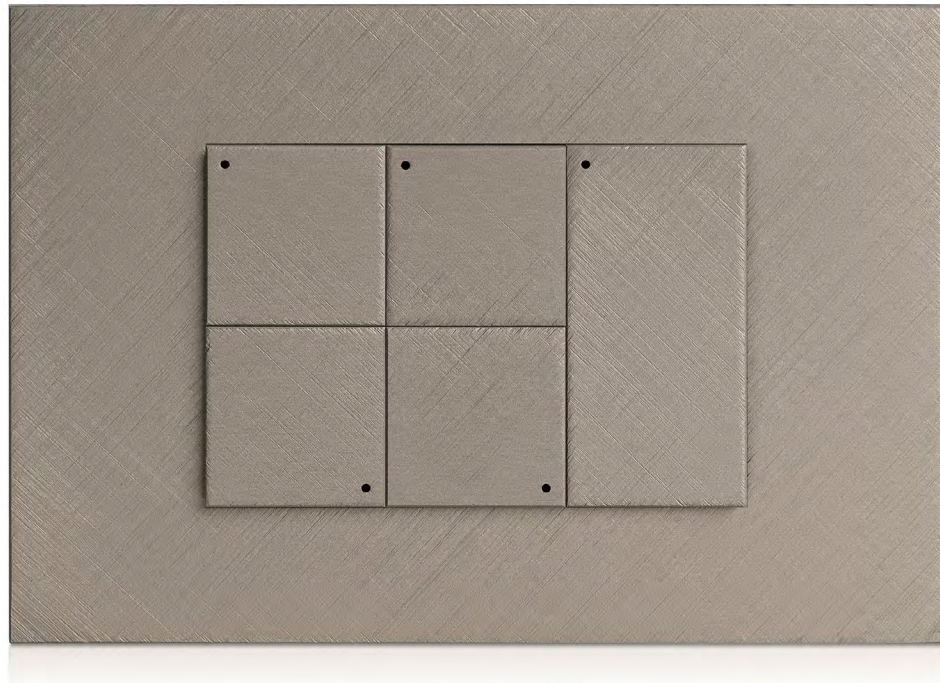

plate

AVAILABLE LAYOUT AND BUTTONS COMBINATIONS

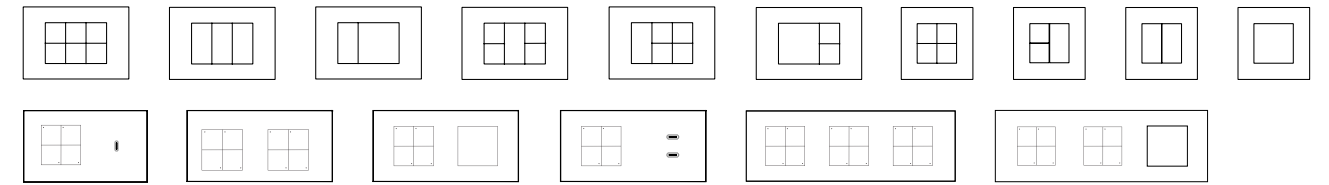

BUTTONS

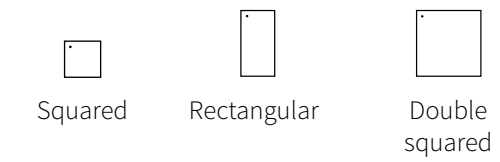

BACKLIT (RGB)

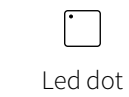

ICONS & SYMBOLS

Laser engraved
custom icons

TECNOLOGY 12/24V



USB-C CHARGERS

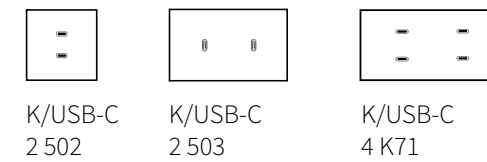

AVAILABLE SIZE



502 503

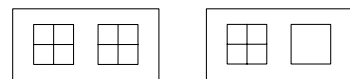

K71 K71MIX

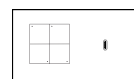

504 - USBC

SOCKETS

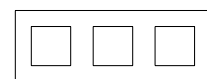
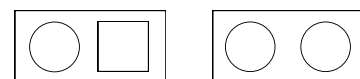
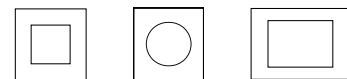

CUSTOM SHAPES AVAILABLE

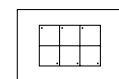

Round angle
Round edge
Sharp edge

KPLATE® 502

MECHANICAL CHARACTERISTICS (MM)

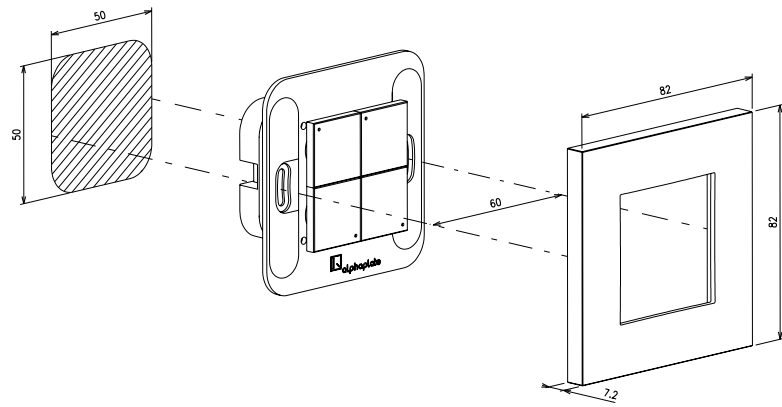

DIMENSIONS (MM)

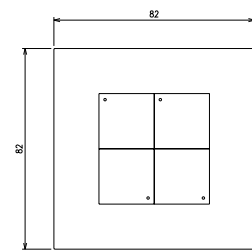

Front view

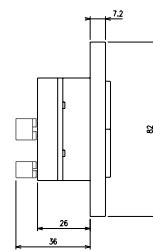

BUS Side view

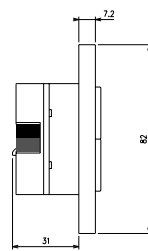

KNX Side view

KPLATE® 503

MECHANICAL CHARACTERISTICS (MM)

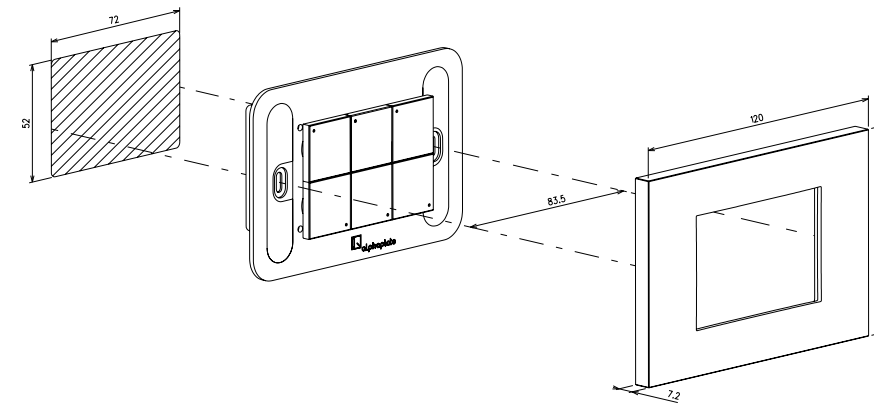

DIMENSIONS (MM)

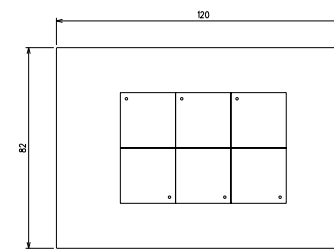

Front view

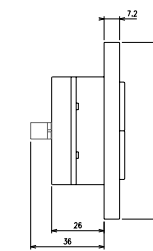

BUS Side view

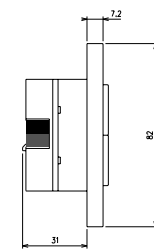

KNX Side view

KPLATE® K71

MECHANICAL CHARACTERISTICS (MM)

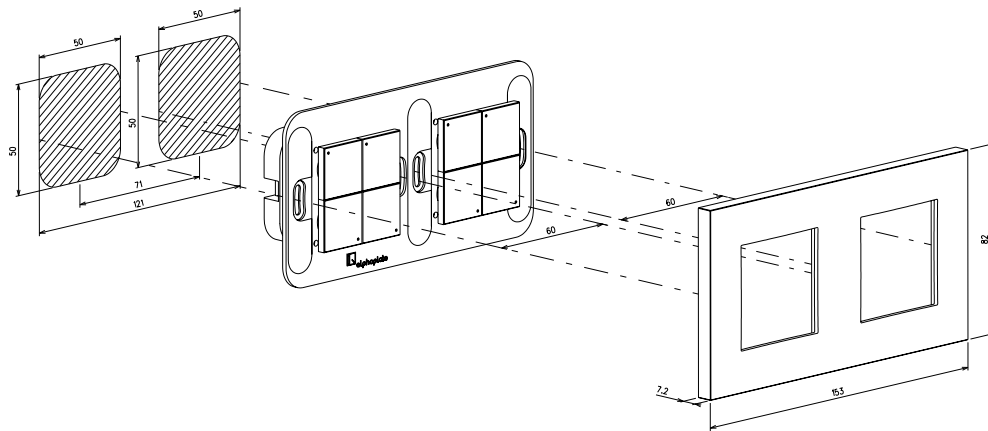

DIMENSIONS (MM)

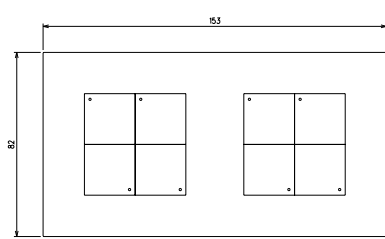

Front view

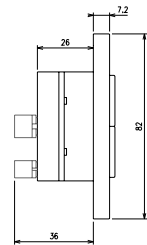

BUS Side view

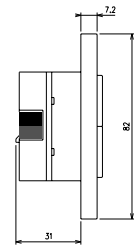

KNX Side view

KPLATE® K71MIX

MECHANICAL CHARACTERISTICS (MM)

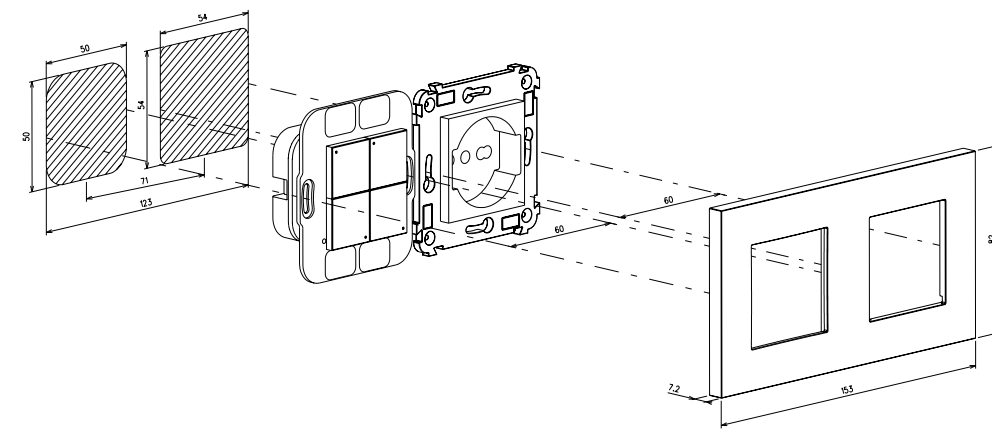

DIMENSIONS (MM)

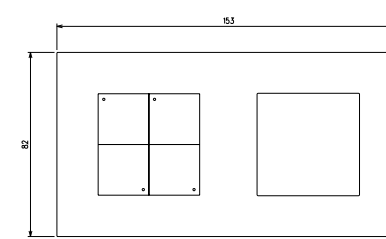

Front view

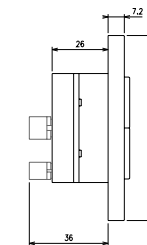

BUS Side view

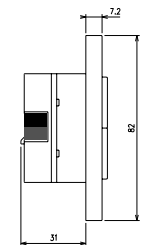

KNX Side view

KPLATE® 142

MECHANICAL CHARACTERISTICS (MM)

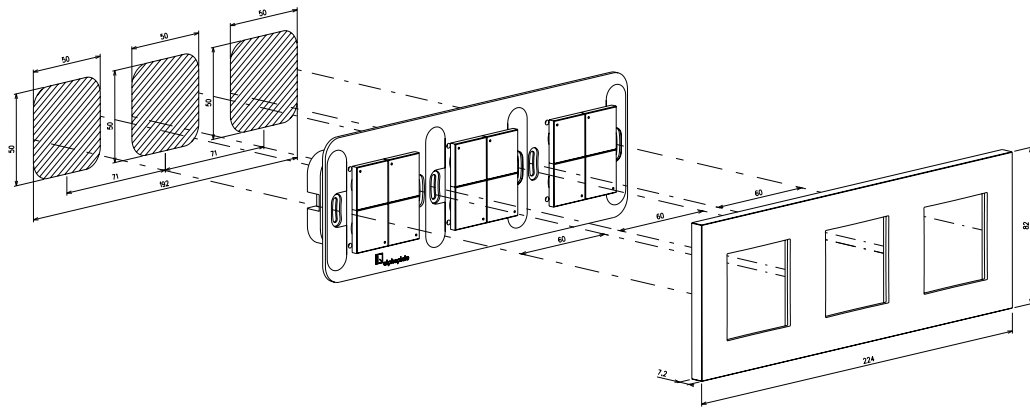

DIMENSIONS (MM)

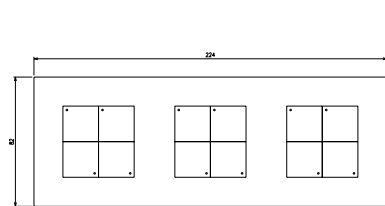

Front view

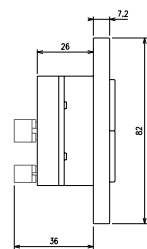

BUS Side view

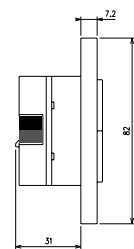

KNX Side view

KPLATE® 142 MIX

MECHANICAL CHARACTERISTICS (MM)

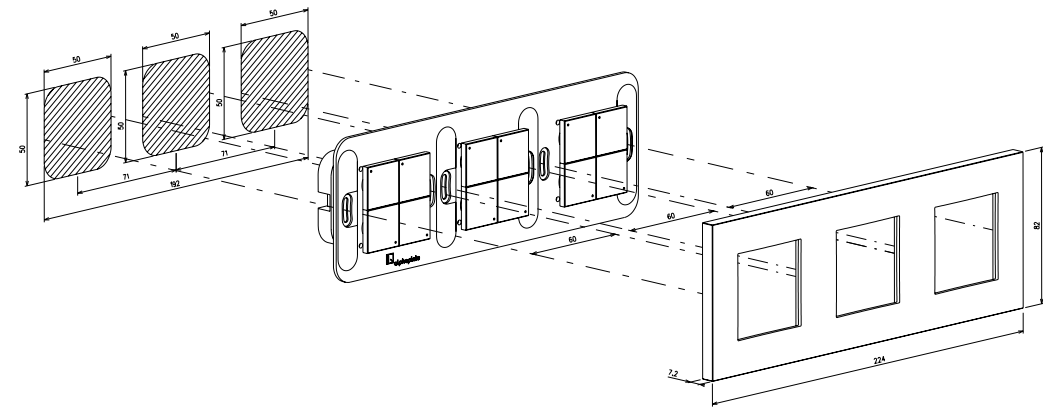

DIMENSIONS (MM)

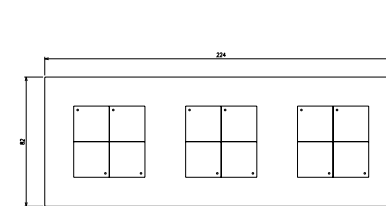

Front view

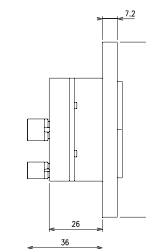

BUS Side view

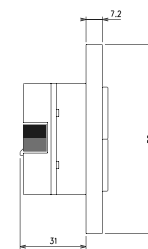

KNX Side view

KPLATE® SOCKET

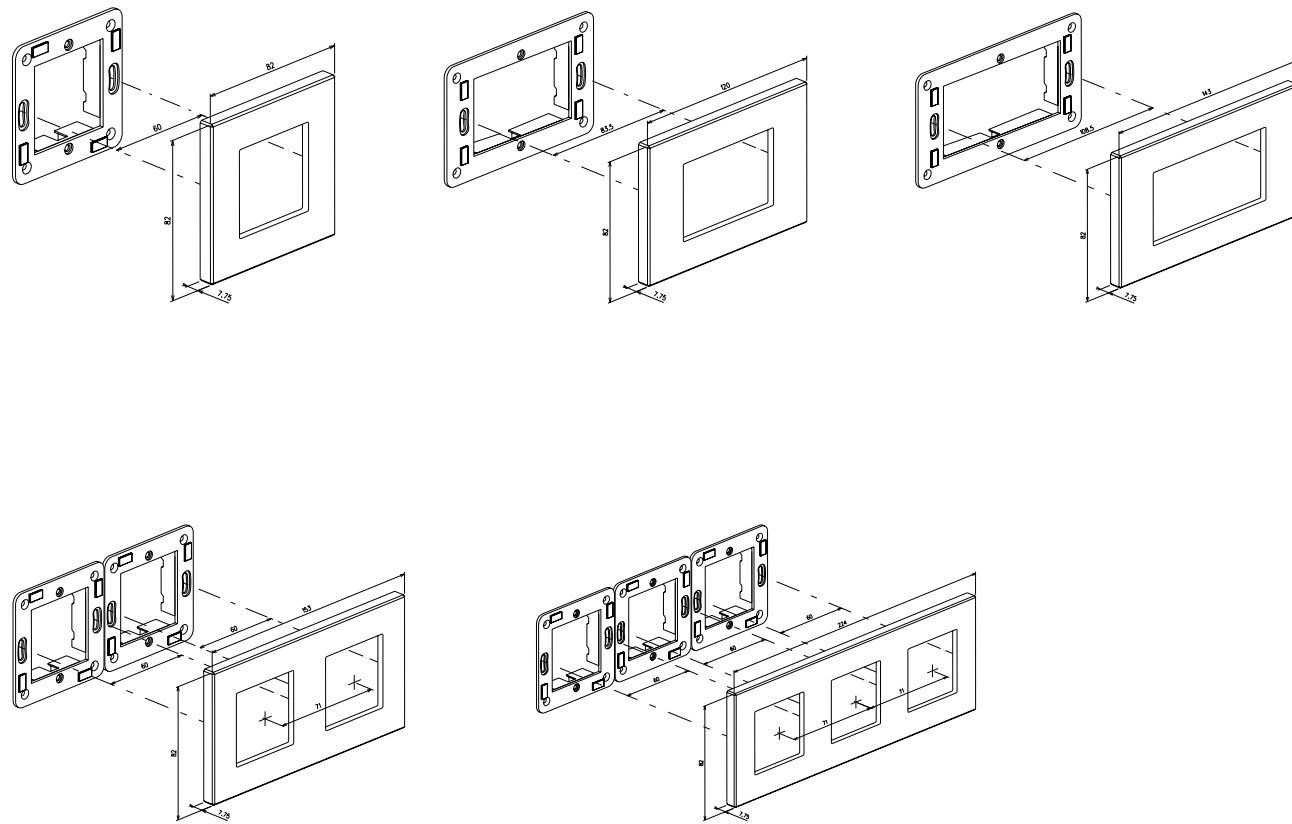

KPLATE® BUTTONS

KPLATE CAN BE CONFIGURED
TO CONTAIN UP TO 12 SINGLE BUTTONS.)

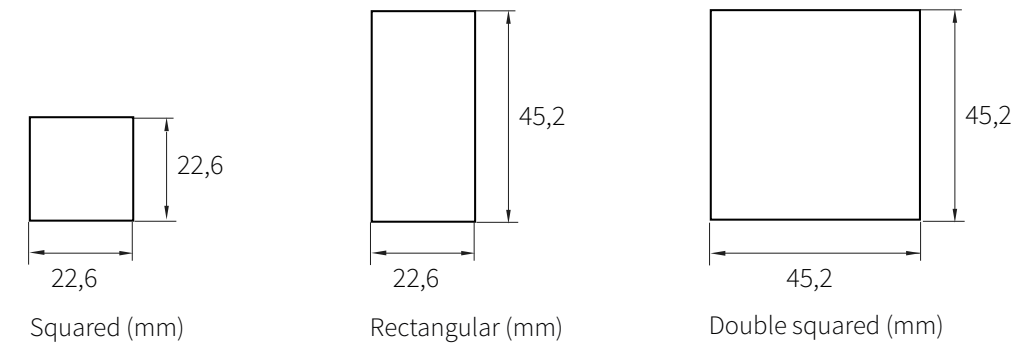

KPLATE® LAYOUT

503

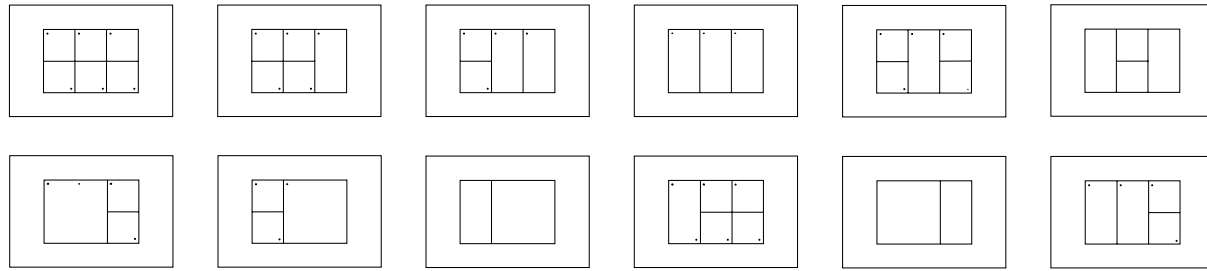

502

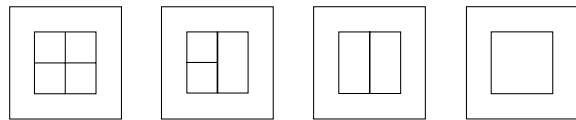

K71

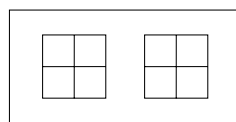

K71 MIX

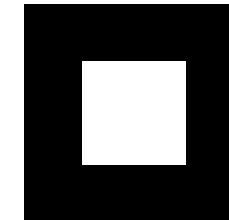
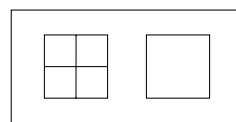

KPLATE® LASER - ENGRAVED ICONS

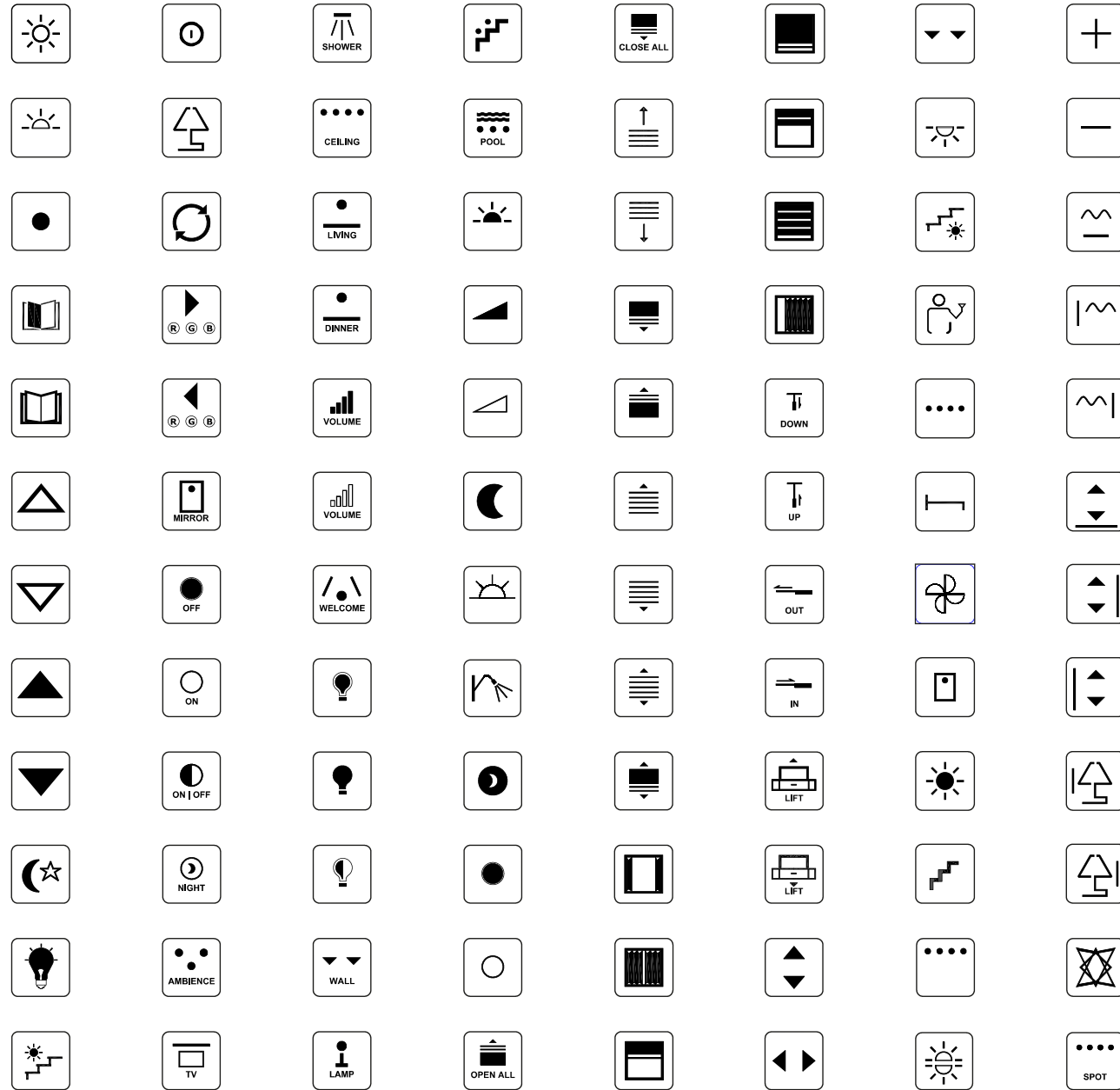

KPLATE® LASER - ENGRAVED ICONS

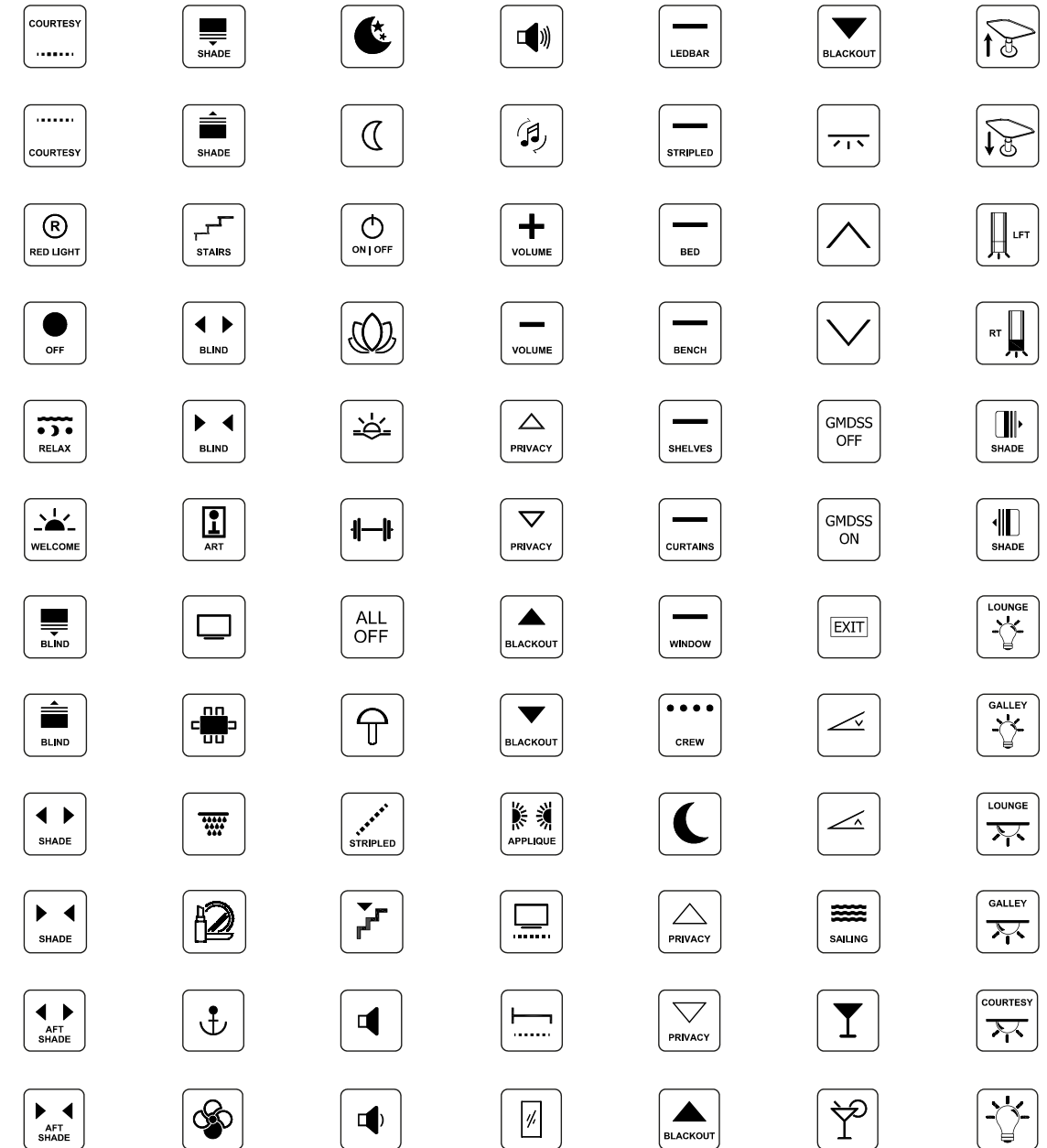

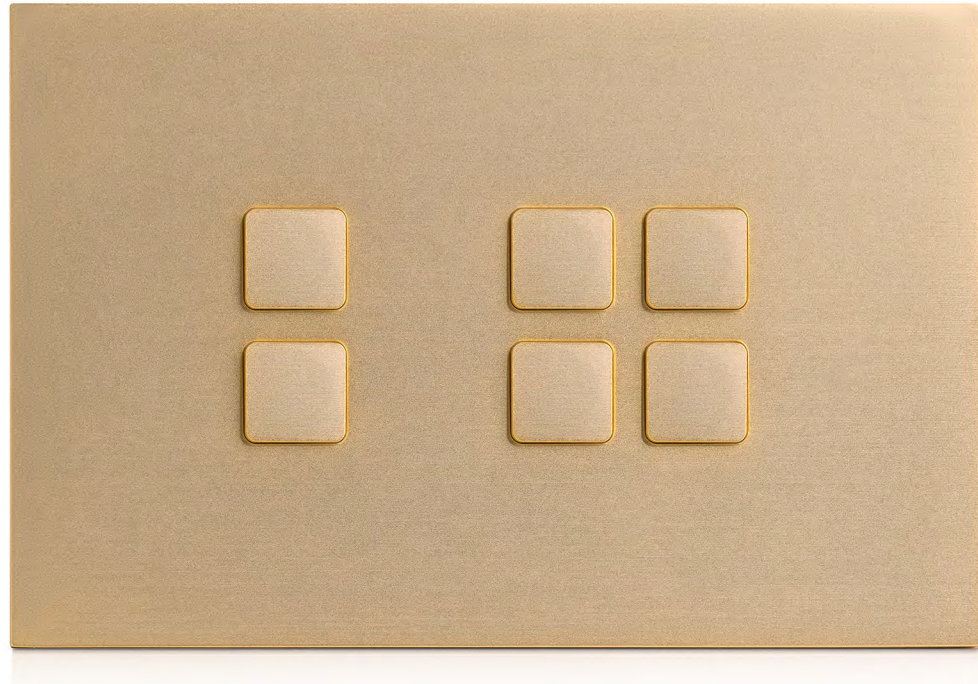

H plate

ENDLESS LAYOUT AND BUTTONS COMBINATIONS

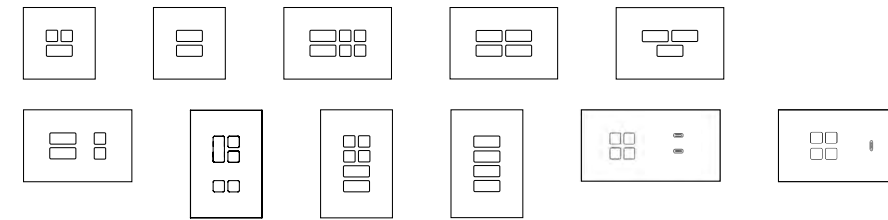

BUTTONS

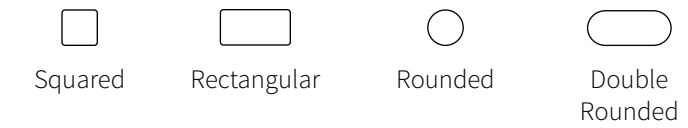

BACKLIT (BLUE OR WHITE)

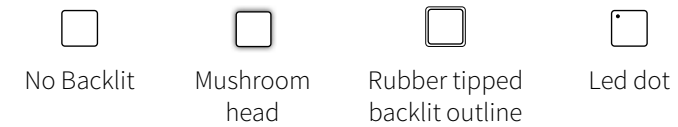

ICONS & SYMBOLS

Laser engraved
custom icons

ELECTRONICS



USB-C CHARGERS

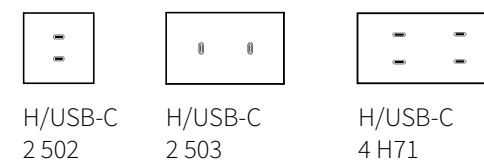

AVAILABLE SIZE

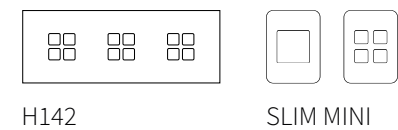
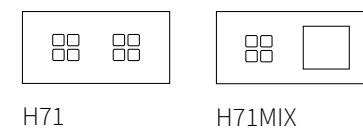
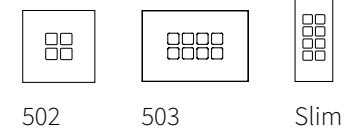

SOCKETS

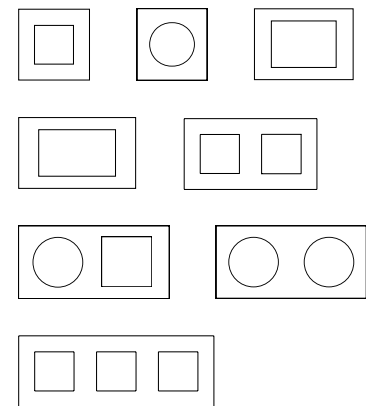

CUSTOM SHAPES AVAILABLE

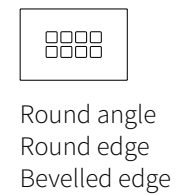

Round angle
Round edge
Bevelled edge

HPLATE® BACKLIT CHOICE



Squared buttons
White mushroom-head backlit

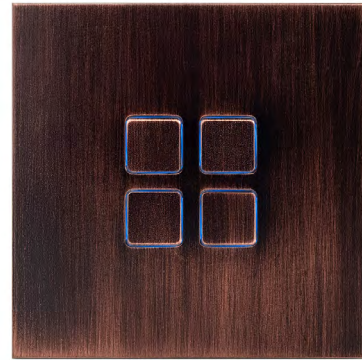

Squared buttons
Blue mushroom-head backlit



Squared buttons
Whole button (No backlit)



Rounded buttons
Whole button (No backlit)



Squared buttons
Whole button (No backlit)



Squared buttons
Blue led backlit dot



Squared buttons
Whole button (no backlit)



Rectangular buttons
Backlit

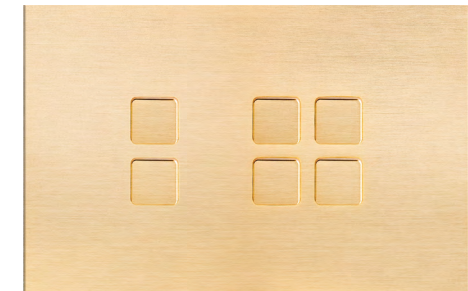

Squared buttons
Backlit

HPLATE® BACKLIT BUTTON SHAPES

HPLATE® 502

MECHANICAL CHARACTERISTICS (MM)

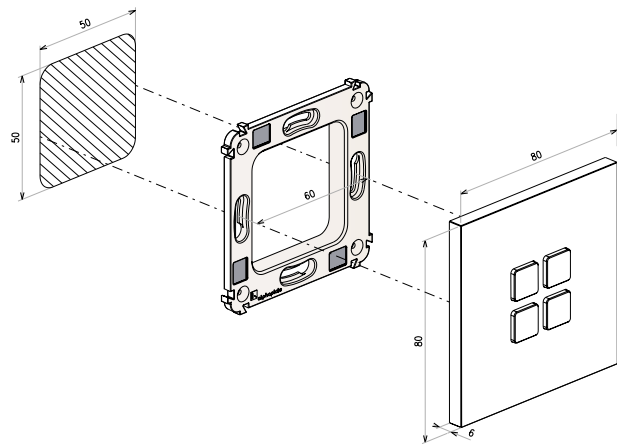

DIMENSIONS (MM)

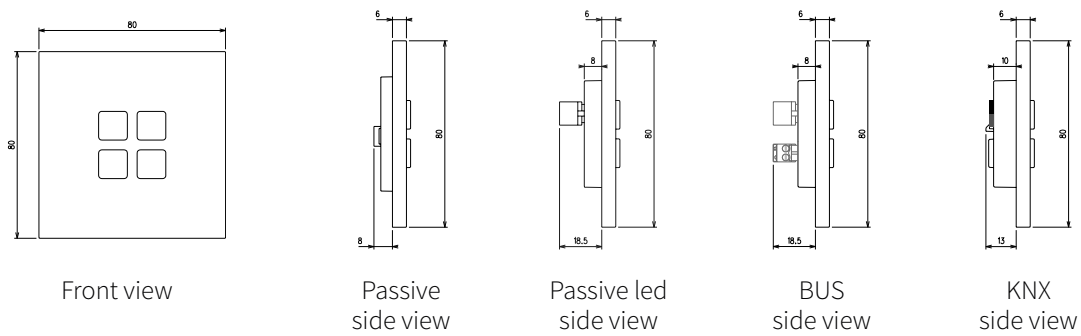

HPLATE® 503

MECHANICAL CHARACTERISTICS (MM)

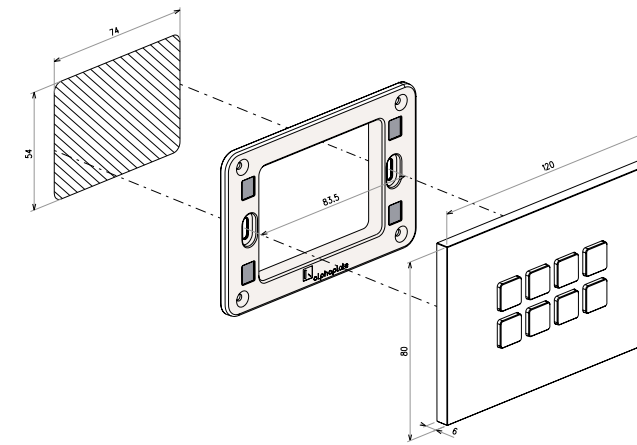

DIMENSIONS (MM)

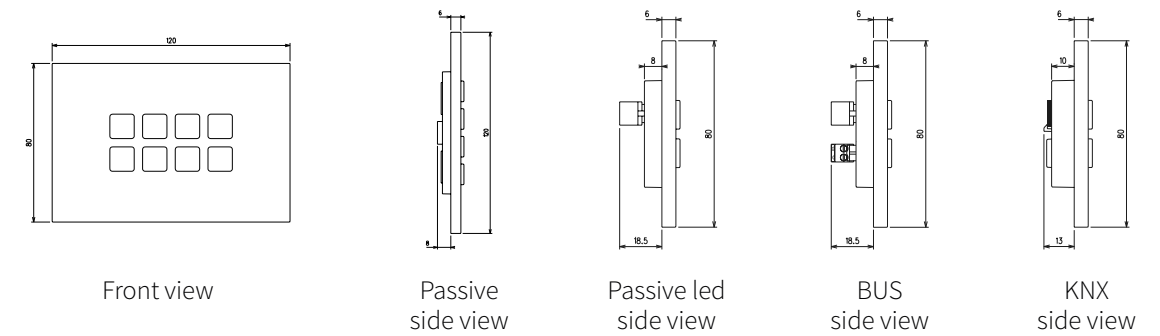

HPLATE® SLIM

MECHANICAL CHARACTERISTICS (MM)

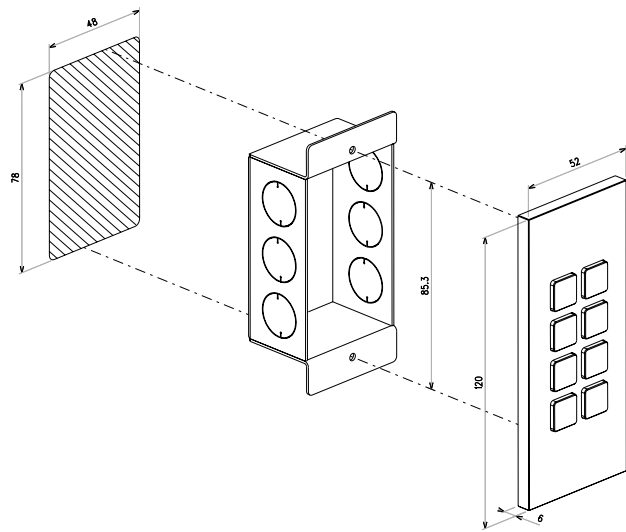

DIMENSIONS (MM)

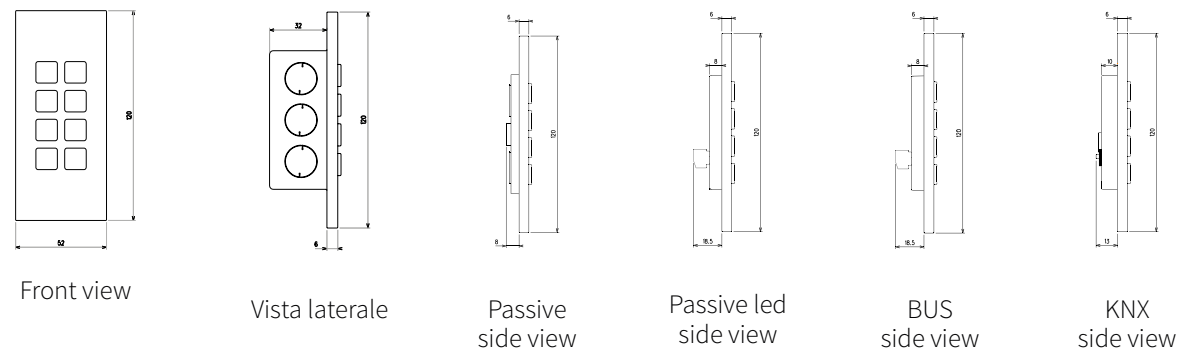

HPLATE® H71

MECHANICAL CHARACTERISTICS (MM)

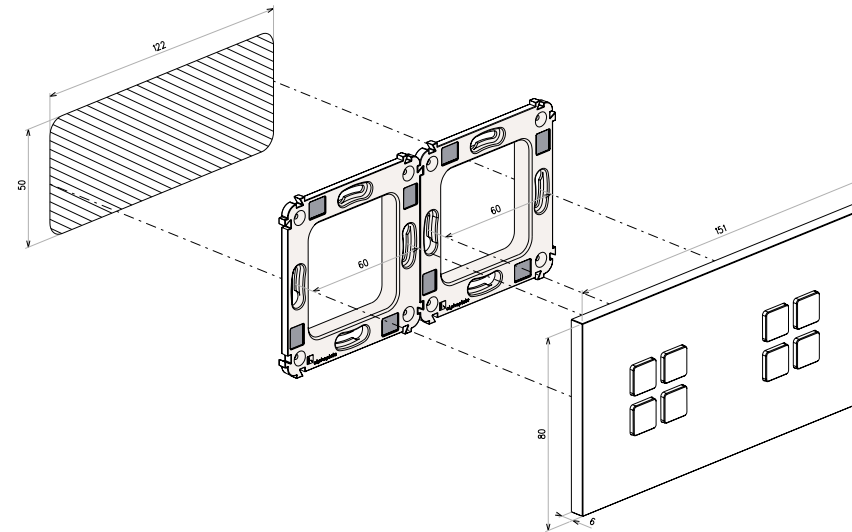

DIMENSIONS (MM)

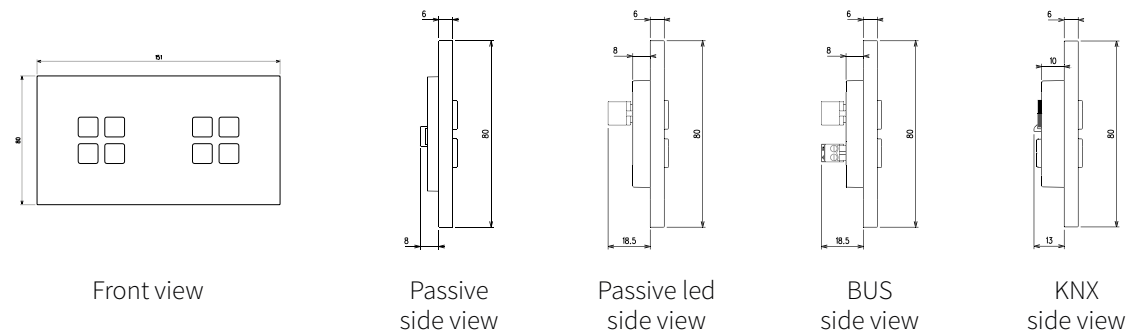

HPLATE® H71MIX

MECHANICAL CHARACTERISTICS (MM)

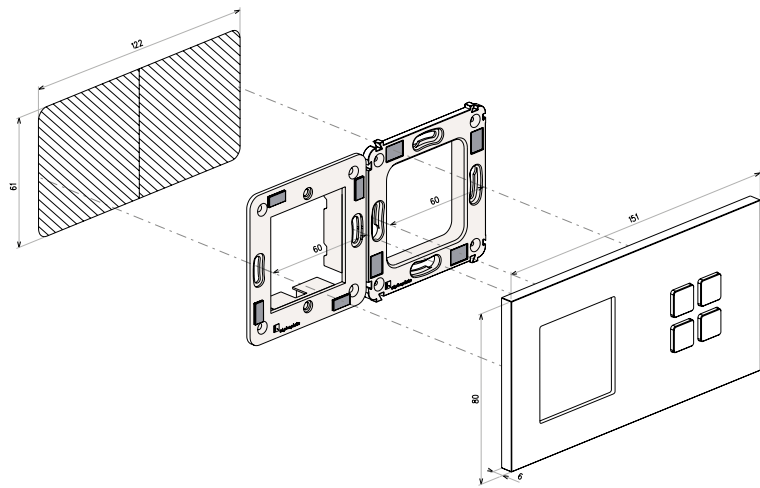

DIMENSIONS (MM)

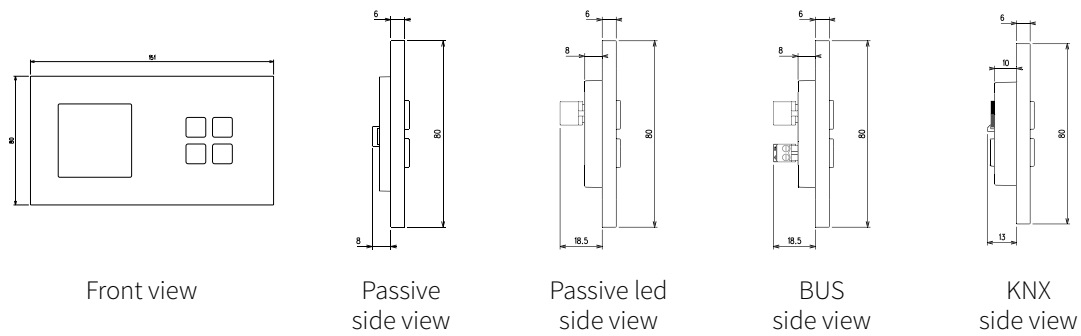

Front view

Passive side view

Passive led side view

BUS side view

KNX side view

HPLATE® H142

MECHANICAL CHARACTERISTICS (MM)

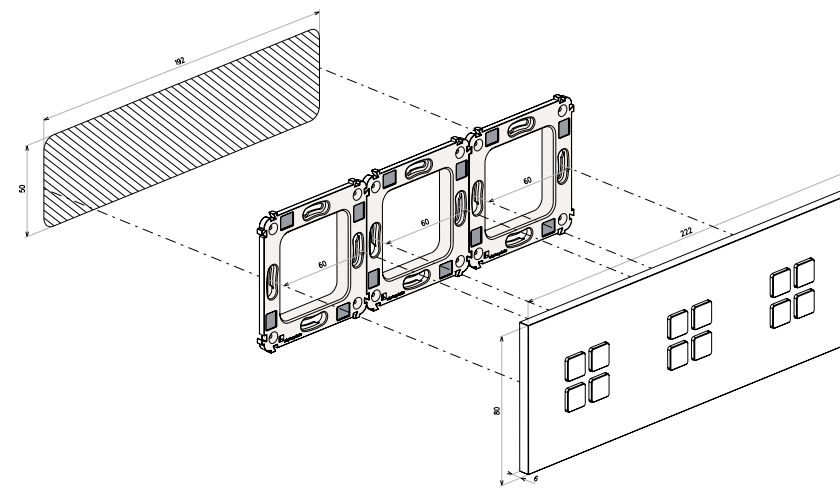

DIMENSIONS (MM)

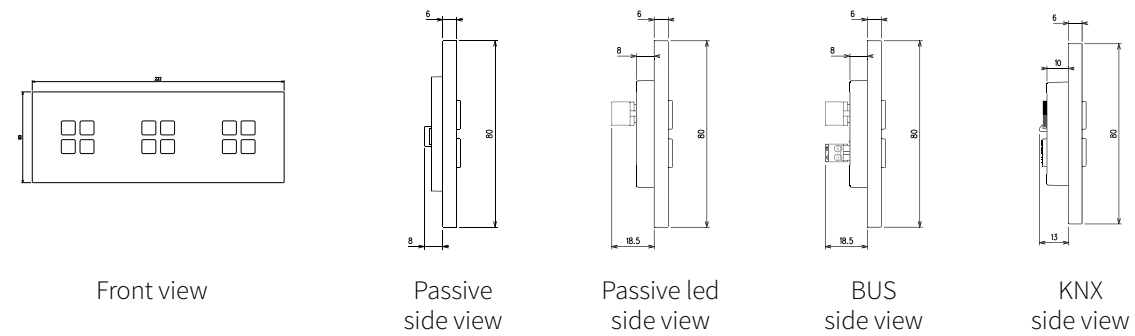

Front view

Passive side view

Passive led side view

BUS side view

KNX side view

HPLATE® H142MIX

MECHANICAL CHARACTERISTICS (MM)

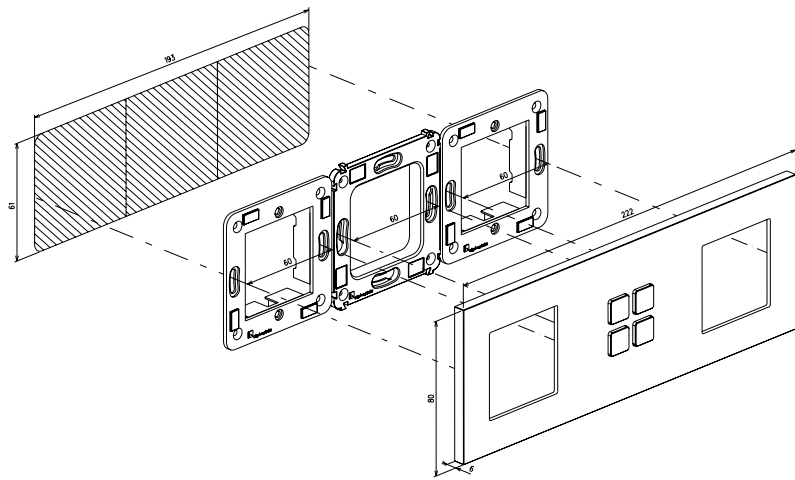

DIMENSIONS (MM)

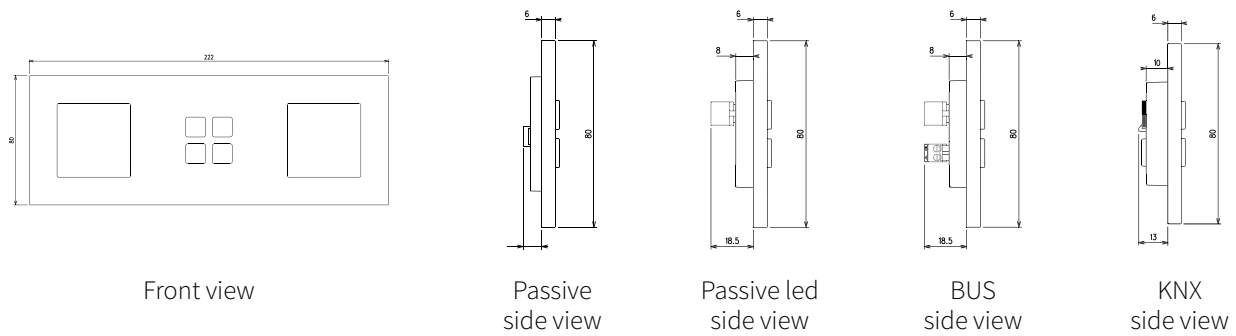

HPLATE® BUTTONS

HPLATE CAN BE CONFIGURED TO CONTAIN UP TO 12 SINGLE BUTTONS.

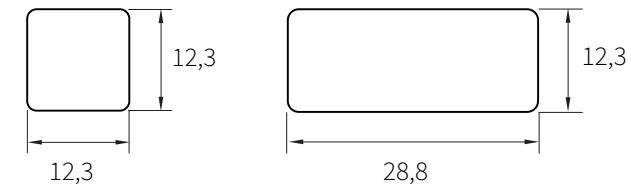

Squared single & double (mm)

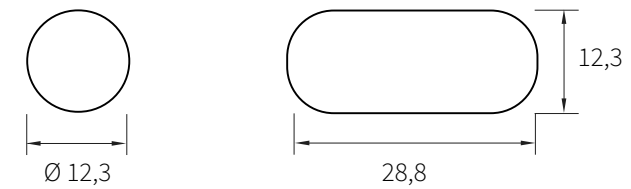

Rounded single & double (mm)

HPLATE® SOCKET

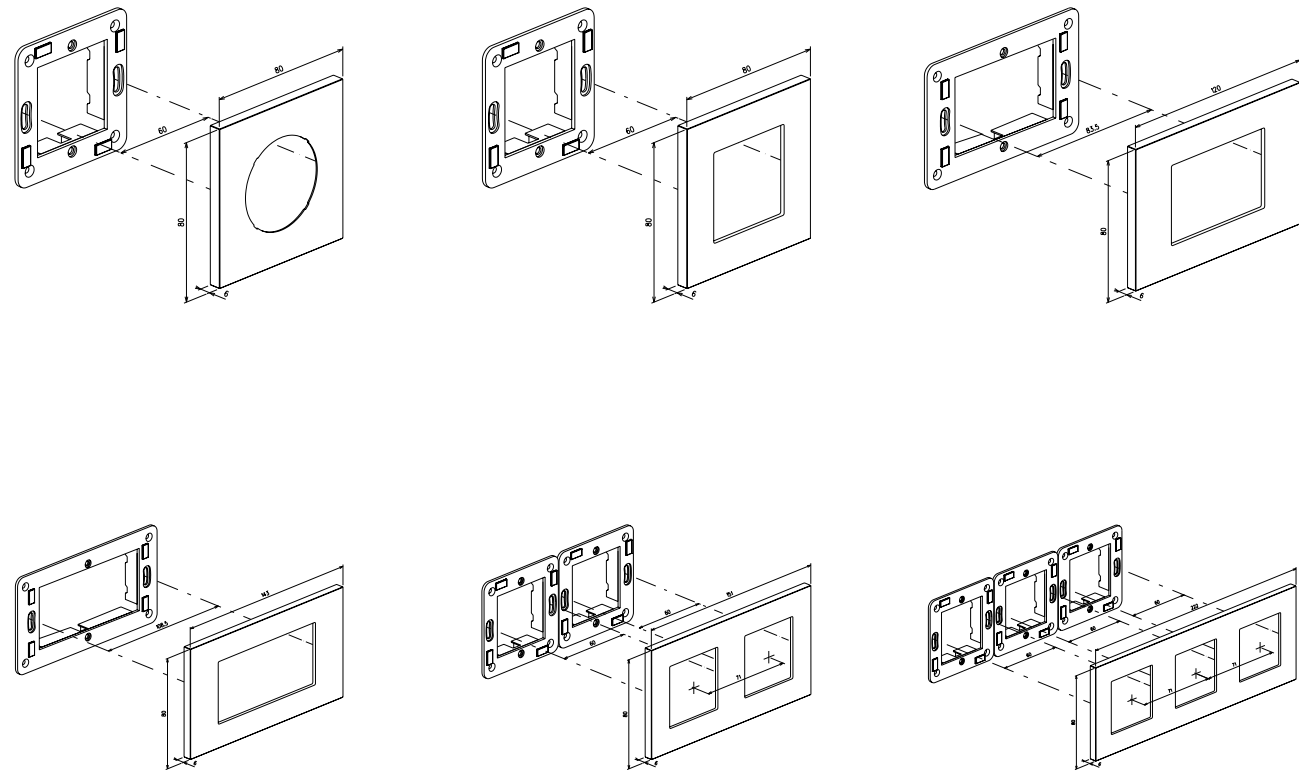

HPLATE® LAYOUT

503

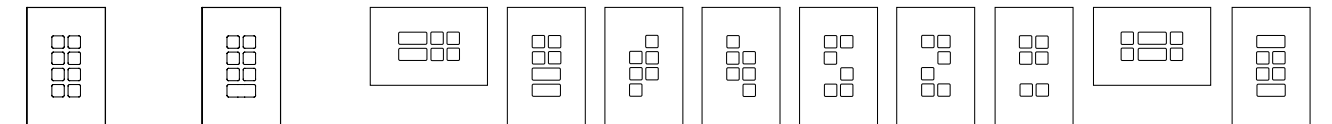

8 buttons 7 buttons 6 buttons



5 buttons 4 buttons

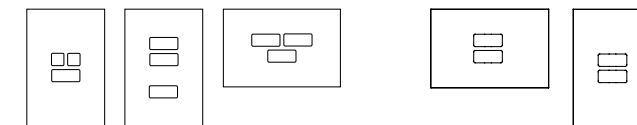

3 buttons 2 buttons

503 SLIM



502

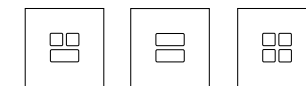

H71

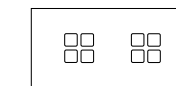

H71 MIX

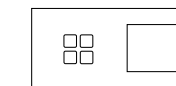

H142

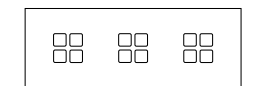

HPLATE® ENGRAVED ICONS

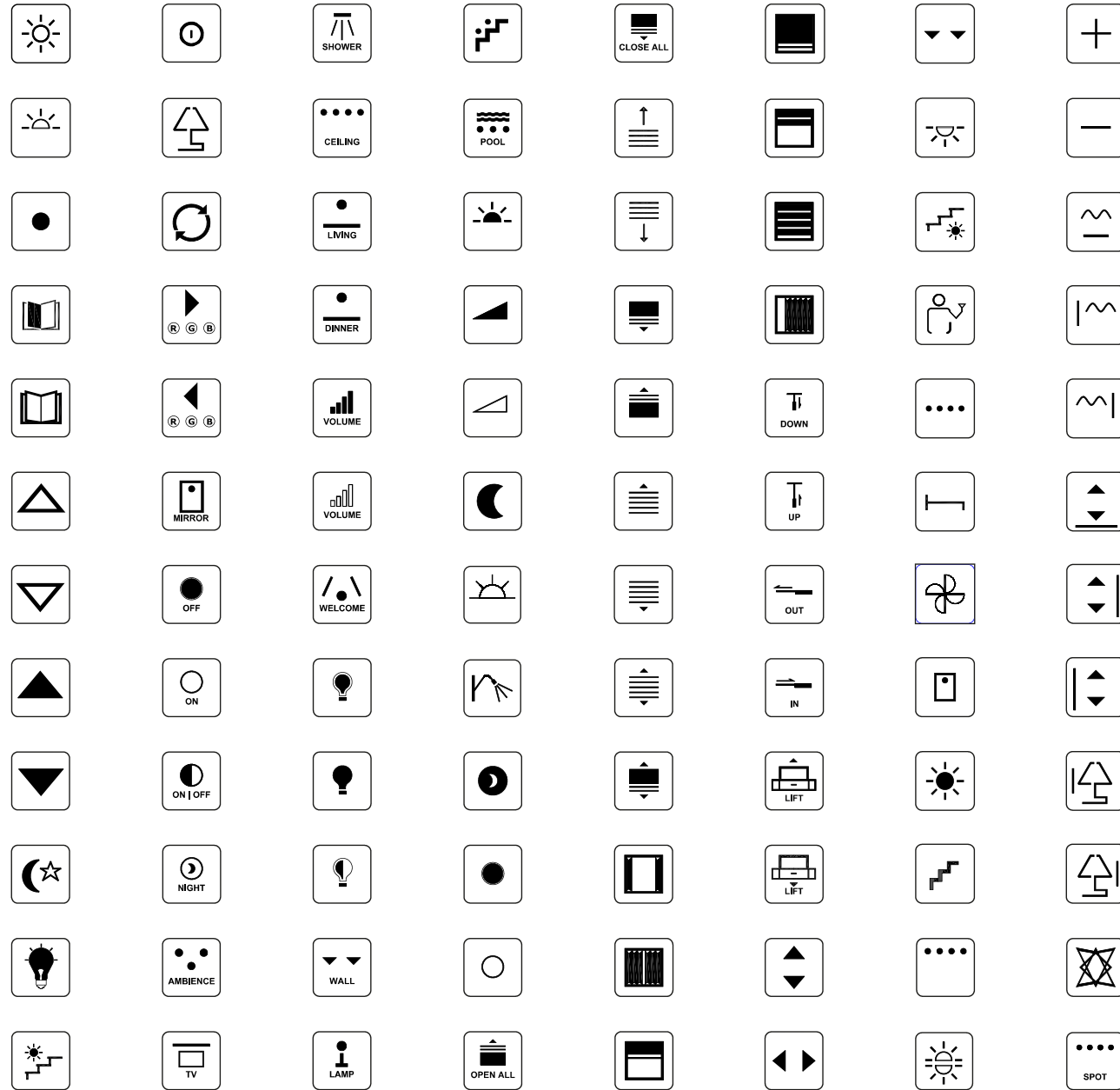

HPLATE® ENGRAVED ICONS

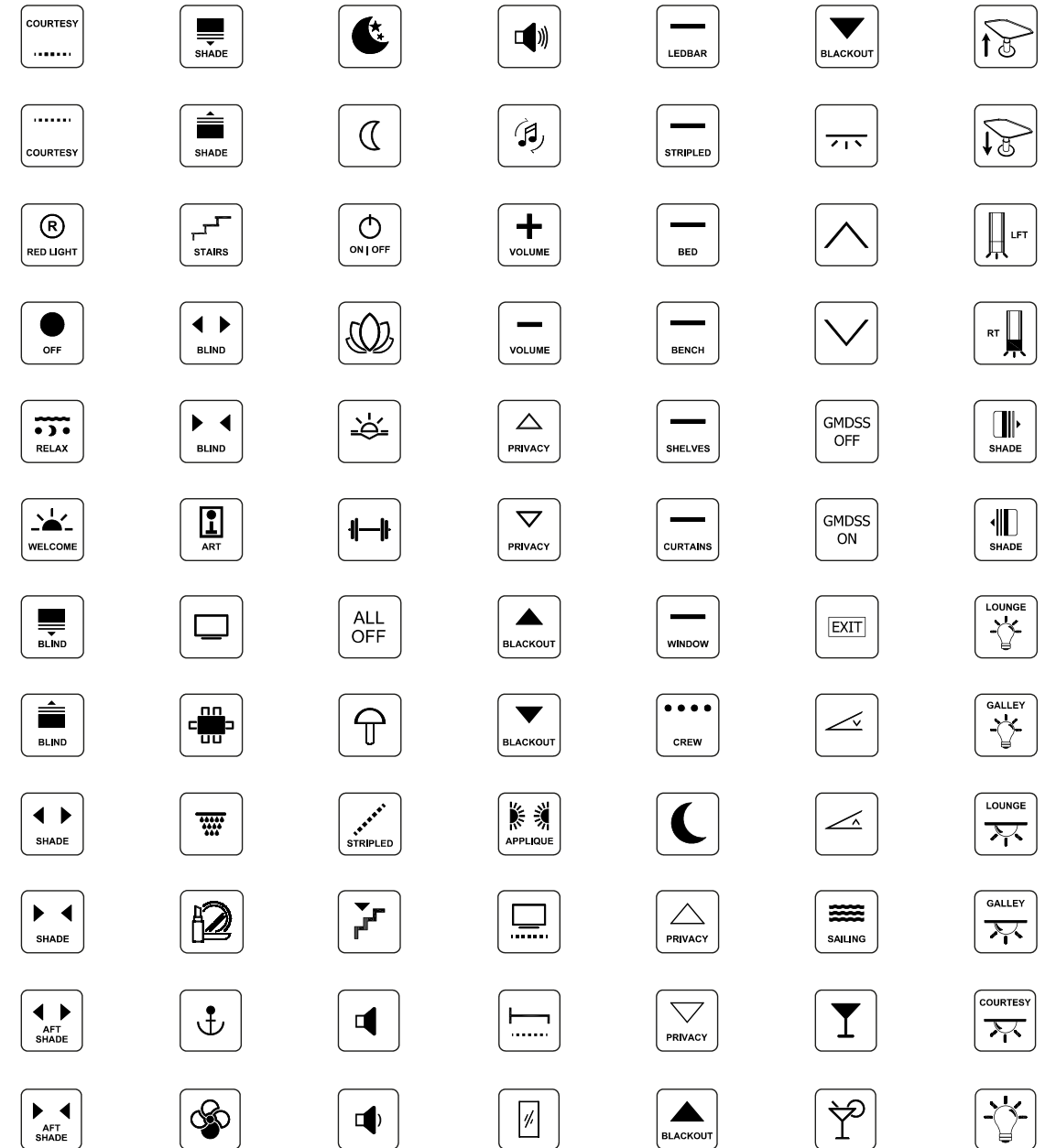

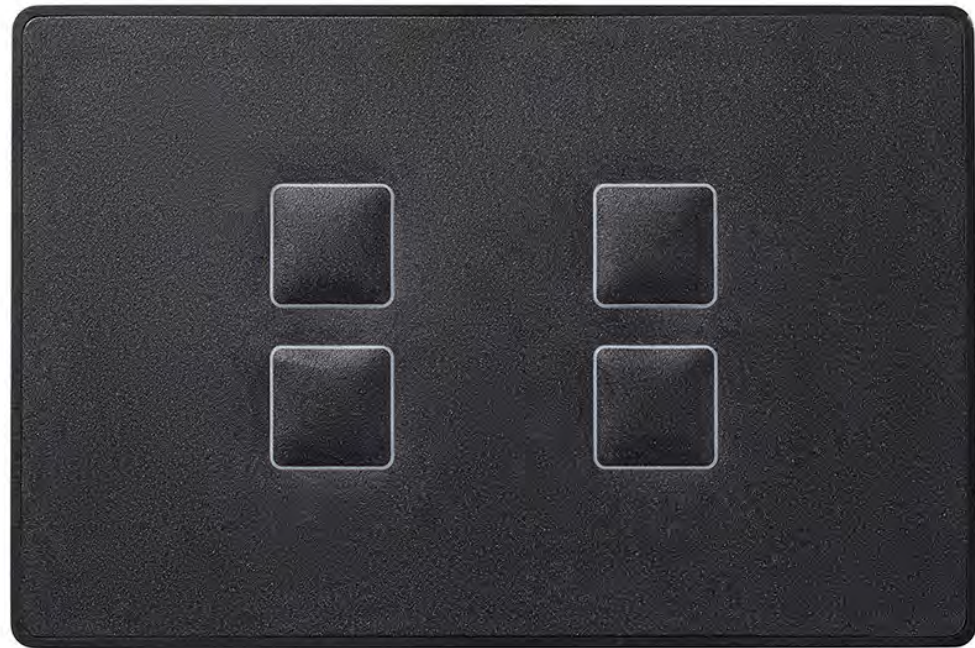

plate

FRAMES



Fully customizable

ENDLESS LAYOUT AND BUTTONS COMBINATIONS

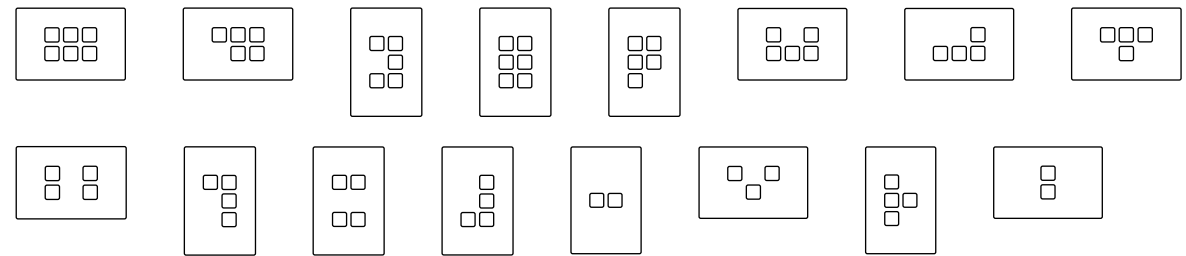

BUTTONS



Squared

BACKLIT



Blue
or White

ICONS & SYMBOLS

Silkscreen
custom icons

TECNOLOGY 12/24V



ITALIAN STANDARD



503

SOCKETS



SHAPES AVAILABLE

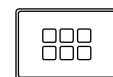

Bevelled angles
and edges



plate 67

ITALIAN STANDARD

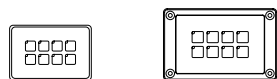

Mini Standard

SHAPES AVAILABLE



Bevelled angles and edges

FRAMES



Fully customizable

ENDLESS LAYOUT AND BUTTONS COMBINATIONS

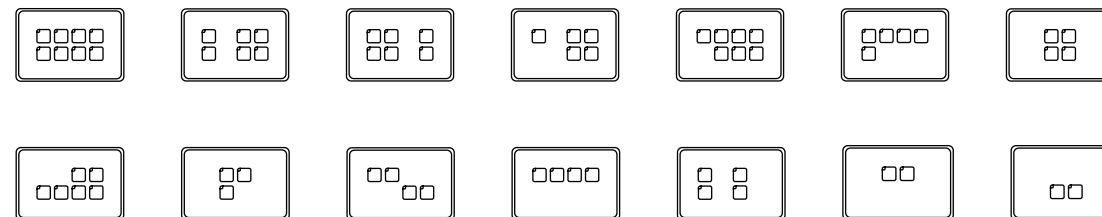

BUTTONS



Squared

BACKLIT



Blue or White

ICONS & SYMBOLS

Silkscreen printed custom icons

TECNOLOGY 12/24V



+ HPLATE® 502

MECHANICAL CHARACTERISTICS (MM)

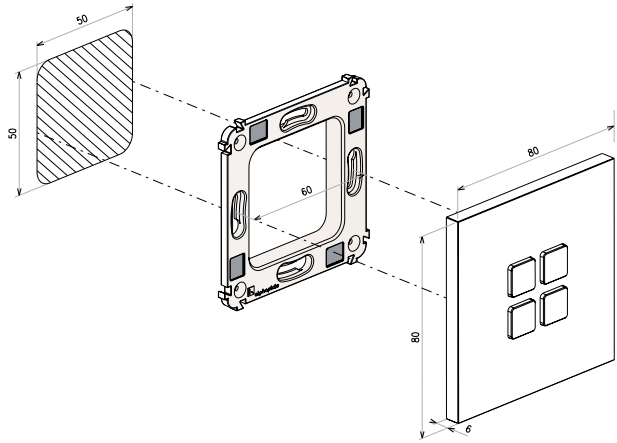

DIMENSIONS (MM)

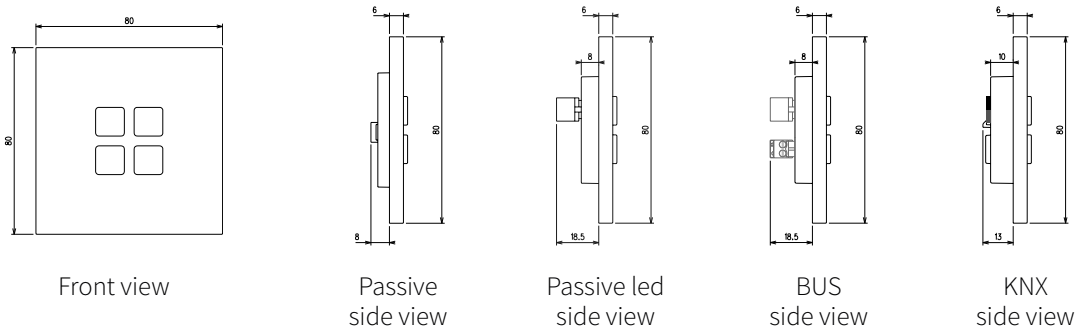

+ KPLATE® 502

MECHANICAL CHARACTERISTICS (MM)

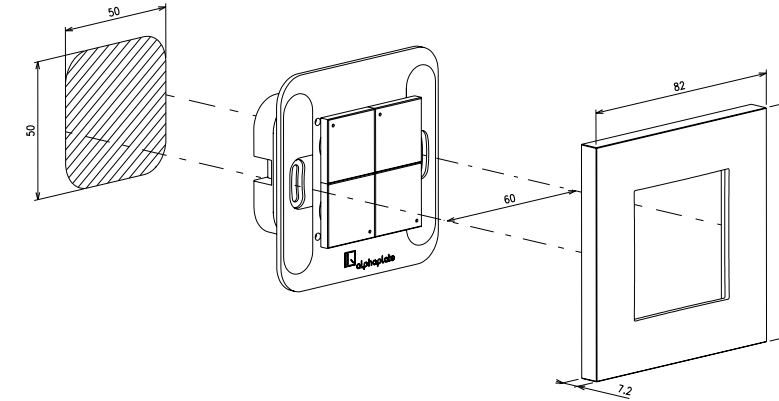

DIMENSIONS (MM)

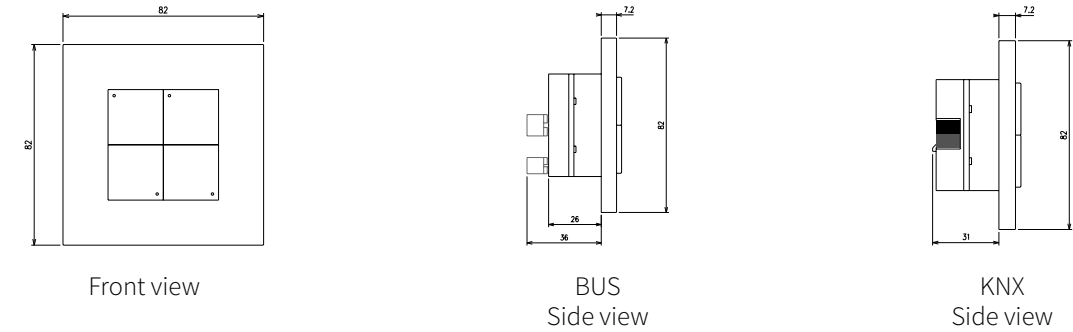



V.Y.C. Srl

Via Marina di Levante, 3 | 55049 Viareggio (LU) Italy
Tel. +39 0584 383354 | Fax. +39 0584 383270 | info@alphaplate.it

www.alphaplate.it

